

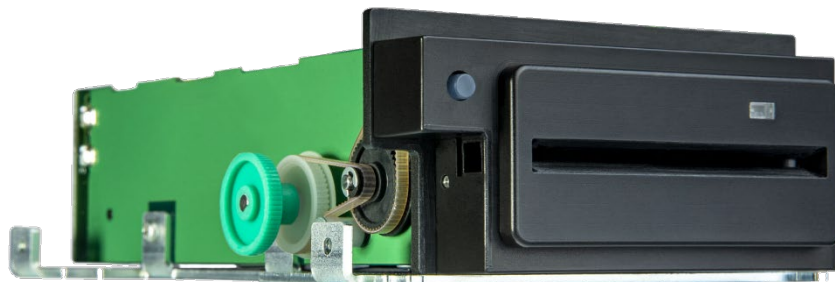

ViVOpay™ VP5300M Integration Manual



80171500-001 Rev. P

14 August 2023

ID TECH
10721 Walker Street, Cypress, CA 90630-4720
Tel: (714) 761-6368 Fax (714) 761-8880
www.idtechproducts.com

Copyright© 2023 International Technologies and Systems Corporation. All rights reserved.

ID TECH
10721 Walker Street
Cypress, CA 90630 USA

This document, as well as the hardware and software it describes, is furnished under license and may only be used in accordance with the terms of such license. The content of this paper is furnished for informational use, subject to change without notice, and not to be construed as a commitment by ID TECH. ID TECH assumes no responsibility or liability for any errors or inaccuracies that may appear in this document.

Except as permitted by such license, no part of this publication may be reproduced or transmitted by electronic, mechanical, recorded, or any other method, or translated into another language or language form without the express written consent of ID TECH. ID TECH is a registered trademark of International Technologies and Systems Corporation. ViVOPay and Value through Innovation are trademarks of International Technologies and Systems Corporation. Other trademarks are the property of the respective owner.

Warranty Disclaimer: The services and hardware are provided "as is" and "as-available," and the use of these services and hardware are at the user's own risk. ID TECH does not make, and hereby disclaims, any and all other express or implied warranties, including, but not limited to warranties of merchantability, title, fitness for a particular purpose, and any warranties arising from any course of dealing, usage, or trade practice. ID TECH does not warrant that the services or hardware will be uninterrupted, error-free, or completely secure.



CAUTION: Risk of Explosion if Battery is replaced by an Incorrect Type. Dispose of Used Batteries According to the Instructions.

Revision History

Date	Revision	Changes	Author
04/07/2021	L	Reimplemented Revision History log Restored Applicable Documents section	CB
06/30/2021		Added section about SmartPIN L100 removal detection sensor	CB
10/07/2021	M	Updated Diagnostic LED Status table	CB
12/01/2021	N	Updated cleaning information, added notes about outdoor installation requirements	CB
08/01/2022	O	Added battery warning text to preamble.	CB
08/14/2023	P	Updated external links.	CB

Table of Contents

1. OVERVIEW	6
1.1. Applicable Documents	7
1.2. Features	7
1.3. VP5300M: Approvals.....	8
2. VP5300M ELECTRICAL REQUIREMENTS.....	9
3. VP5300M SPECIFICATIONS.....	9
4. VP5300M 3-VIEW DRAWING.....	11
5. NFC ANTENNA 3-VIEW	13
6. VP5300M INSTALLATION	14
6.1. Parts List.....	14
6.2. Installing the Reader.....	14
6.2.1. Protective Plastic Film.....	14
6.3. Mounting the VP5300M External NFC Antenna.....	15
6.3.1. Flush-Mounting the Antenna.....	18
6.4. VP5300M Connectors.....	18
6.5. Attaching the Cables from the Antenna to the VP5300M.....	19
6.6. Connecting to Power	19
6.7. Connecting to the Data Port.....	20
6.8. VP5300M External Cable Pin Assignments: RS-232	20
6.9. VP5300M External Cable Pin Assignments: USB	20
6.10. Installation Notes.....	21
7. LED MANAGEMENT	22
7.1. Front LED Status.....	22
7.2. RF LED Status.....	22
7.3. Diagnostic LED Status.....	23
8. WARPED CARD SUPPORT.....	23
9. USING THE VP5300M TO MAKE A CONTACTLESS PURCHASE.....	24
9.1. Presenting Proximity Cards or NFC Phones.....	24
10. MAINTENANCE.....	25
10.1. Cleaning the VP5300M	25
10.1.1. Cleaning the Magnetic Heads.....	25
10.1.2. Cleaning the Transportation Rollers.....	25
10.1.3. Cleaning Guidelines	27
11. PAIRING WITH PIN PAD	28
11.1. Setting up the L100 or L80	28
11.2. Setting up the VP5300M.....	29
11.3. Pair the Devices.....	32
11.3.1. Enabling SmartPIN L100 Devices.....	34
11.3.2. Enabling SmartPIN L80 Devices.....	35
11.4. L100 Removal Detection and Paired Readers	35
12. RF INTERFERENCE	36
13. UPDATING VP5300M FIRMWARE.....	37
14. TROUBLESHOOTING.....	39
15. TAMPER AND FAILED SELF-CHECK INDICATORS	41

16. FCC WARNING STATEMENT42
17. IC COMPLIANCE WARNING43
18. CAUTIONS AND WARNINGS43

1. Overview

ID TECH's VP5300M is a motorized, compact SRED credit card reader designed to support MSR (MagStripe) and contact EMV, plus contactless EMV (when the device is mated with the VP5300M's NFC antenna).

The VP5300M is designed to deliver MSR, EMV, and optional NFC (contactless) payment acceptance with SRED security and reliability in unattended payment scenarios, such as Parking, ATM, Ticketing, and Payment Kiosks (among others)¹.

The VP5300M leads the industry in low power consumption and ruggedness, with its plastic bezel and IK07 and IP42 ratings to ensure long life in demanding conditions. The VP5300M is certified to the latest payment standards of EMV (Level 1 and Level 2) and PCI (5.x) and offers easy integration of payments into self-serve kiosk and unattended environments.

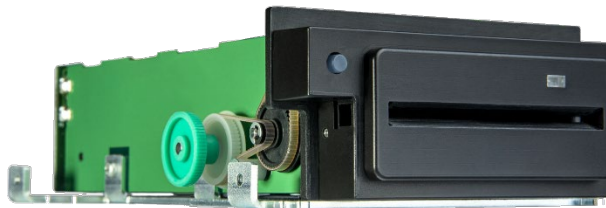

The VP5300M



NFC Antenna

¹ The VP5300M is not for use in outdoor scenarios unless equipped with a cover or shed to protect the reader from water or snow intrusion. Although the product is IK07 and IP42 rated, it cannot withstand water or snow intrusion in outdoor environments.

The VP5300M supports USB and serial (RS-232) host communication using the command protocol defined in the *NEO 2 Interface Developers Guide*. This comprehensive guide describes all the firmware commands and other features available in ID TECH's NEO-series devices; it is the authoritative source for technical information of interest to systems integrators. Contact your ID TECH representative to obtain a copy of this guide, which is available under NDA. Note, also, that a feature-rich, Windows-based Universal SDK is available to aid in rapid development of applications that talk to the VP5300M.

Be sure to check the [VP5300 product page](#) on the ID TECH Knowledge Base for the latest VP5300M demos, utilities, SDK updates, white papers, and other downloads, all of which are freely available without registration.

NOTE: The VP5300M requires the use of an external 12V DC power supply; it cannot run on USB port power alone. When other peripherals are connected to it, such as an NFC antenna, the VP5300M powers those peripherals.

1.1. Applicable Documents

- *ISO 7810 Identification cards: Physical characteristics*
- *ISO 7811 1 - 6 Identification Cards: Track 1 - 3*
- *ISO 7816 Identification cards: Integrated circuit cards*
- *ISO 4909 Magnetic stripe content for track 3*
- *80171400 Product Requirement Document: Motorized PCI SRED / EMV Insert Reader*
- *80000403-001 Enhanced Encrypted MSR Data Output Format*
- *80000404-001 ID-Tech Encrypt Data Format in Command Response Specification*
- *80000405-001 IDTECH NGA Key Injection Protocol*

1.2. Features

The VP5300M supports the following features:

- Contactless: ISO/IEC 14443 Type A and B
- PCI-PTS 5.x certification with SRED
- Tamper responsive (with automatic zeroization of keys in the event of tamper)
- MSR reads up to 3 tracks of data (Bi-Directional), with JIS-I and JIS-II support
- ICC reader with landing contact
- Contact and Contactless EMV Level 1 certified
 - Contact EMV Level 2 certified, using ID TECH's proven Common Kernel
 - All major Contactless kernels supported
- State-of-the-art encryption support
 - Triple DES
 - AES
 - TransArmor RSA
- Support for DUKPT key management (with 15 DUKPT slots) of data and/or MAC keys
- NGA Key Injection Protocol

- TR34 Remote Key Injection Protocol
- 32 Key slots supported
- Optional contactless (NFC/RFID) antenna
- Mechanical and optical combination front switch
- Plastic bezel with a gate
- Dedicated RS232, USB, and Ethernet ports (for data communication)
- Dedicated DC 12 to 24V power input
- LAN with network function 2 colored LEDs for link state and speed indication
- Audio feedback for MSR, contact EMV, and contactless transactions
- RoHS 2, and REACH compliance
- 1-year manufacturer's warranty

This document assumes that users are familiar with their host systems and all related functions.

1.3. VP5300M: Approvals

Item	Regulation & Class
CE	EN55032/EN55035, Class- B
FCC	Part 15, Class-B
RoHS	Compliant
UL	Certification with UL regulation
REACH	Compliance with REACH regulation
USB IF	Compliance with USB IF regulation
EMV	Contact L1 & L2 / Contactless L1
PCI	PCI PTS 5.X Certified
Contactless Technology	Specification Compliance
American Express	American Express® ExpressPay 3.1
Discover	Discover® DPAS 1.0 Zip 3.1.2
MasterCard	MasterCard® MChip 3.1.1
Visa	Visa VCPS 2.2
Interac	Interac 1.5d
CUP	qPBOC 3.0 (ongoing)
JCB	JCB 1.4 (ongoing)
Mobile wallets	Apple Pay Apple VAS Android Pay Google Smart Tap 2.1

2. VP5300M Electrical Requirements

Voltage requirement: 12V DC (minimum) is recommended, to 24V maximum.

Battery: The unit contains a small lithium battery to power the Real Time Clock and certain anti-tamper features. This battery has a shelf life of five years. The battery is not user replaceable. Do not attempt to open the VP5300M for any reason; this will trigger the anti-tamper features, causing the unit to become inoperable. If a replacement battery is required, return the VP5300M to ID TECH. Contact support@idtechproducts.com for more information.

3. VP5300M Specifications

Physical	
VP5300M Reader	163mm from back of mounting surface x 65mm flange width x 27.5 mm flange height (LxWxH)
NFC Antenna Bezel	65mm x 54mm x 14.5mm (LxWxH), not counting 15.5mm-deep M4 studs that protrude from the back of the unit
Structure Material	Plastic bezel, PC UL 94V-0
Housing Color	Black
Weight	0.51 kg without SAM board
Bezel	Plastic bezel with texture
Electrical	
Voltage Requirement	12V DC (minimum) recommended to 24V maximum
Environmental	
Operating Temperature	-0° C to 50° C (32° F to 122° F)
Storage Temperature	-20° C to 70° C (-4° F to 158° F)
Operating Humidity	10% to 95% non-condensing
Storage Humidity	10% to 95% non-condensing
Transit Humidity	5% to 95% non-condensing
Operating Environment	Water resistant for indoor use
IK Rating	IK07
IP Rating	IP42
ESD (Device)²	Air discharge ±15kV (Discharge at Front Bezel Only)
	Contact discharge ±8kV
Impact Resistance	The front face is impact resistant to IK07 rating
Ingress Resistance	The front face meets IP42 rating
Reliability	
Magnetic Head	600,000 cycles minimum
Chassis, card slot	600,000 cycles minimum
Smartcard contact block	600,000 cycles minimum
Bezel and gate	600,000 cycles minimum

² **Note:** Cables and connectors must be fully isolated with insulating material to prevent ESD discharge.

Physical	
Motorized mechanism	600,000 cycles minimum
MTBF	Over 100,000 hours
Receiver Subcarrier Data	ISO 14443-2 Type A/ISO 14443-2 Type B: ISO 18092
Typical Read Range	0~4cm(0~1.5 inches)

4. VP5300M 3-View Drawing

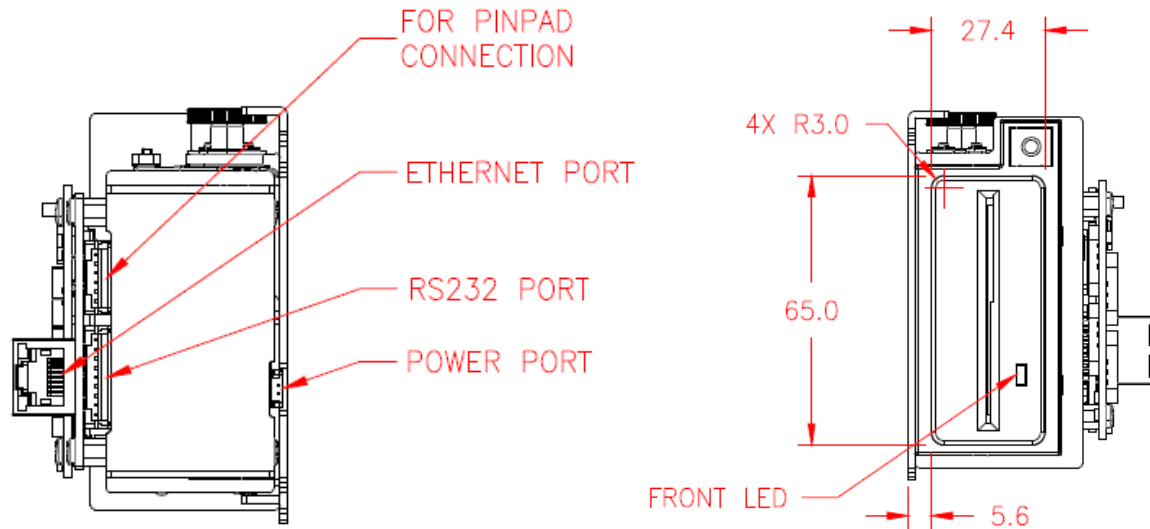
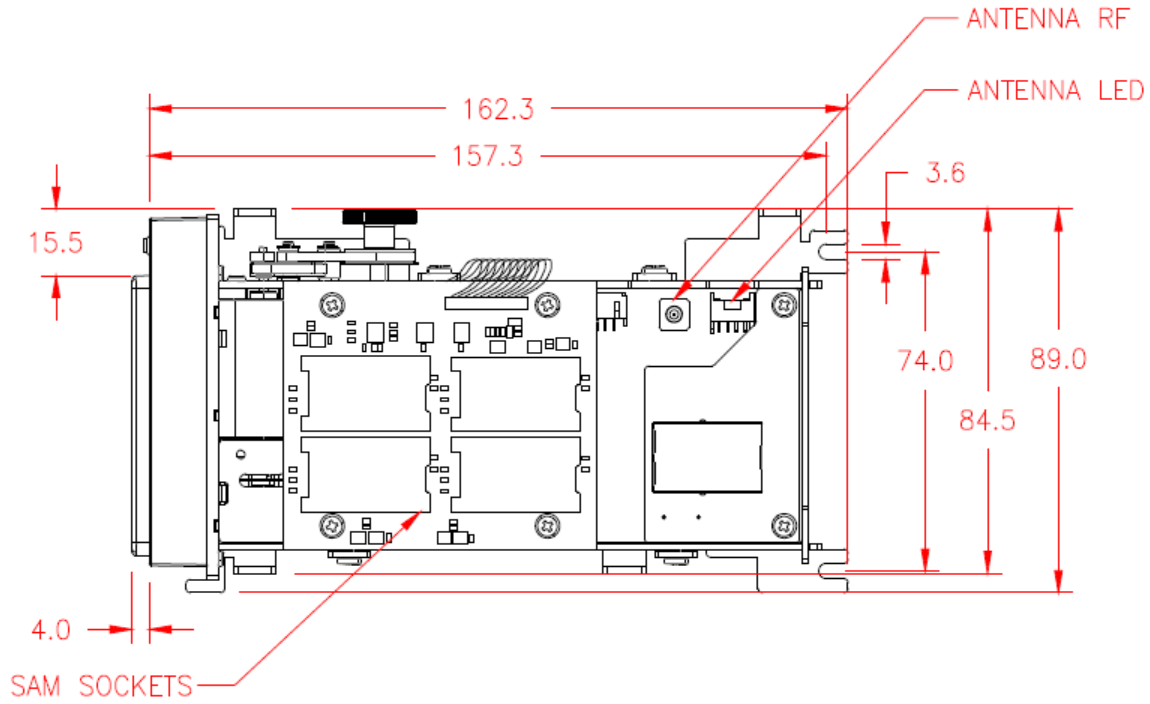
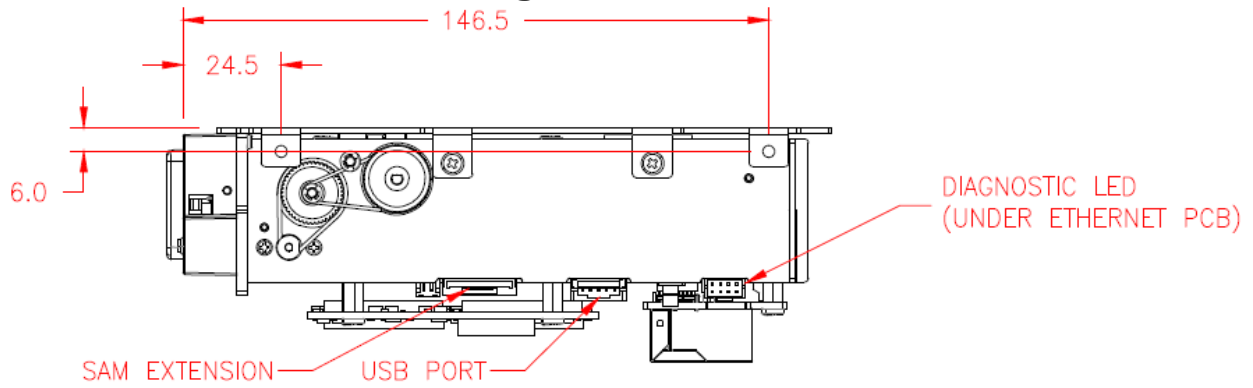

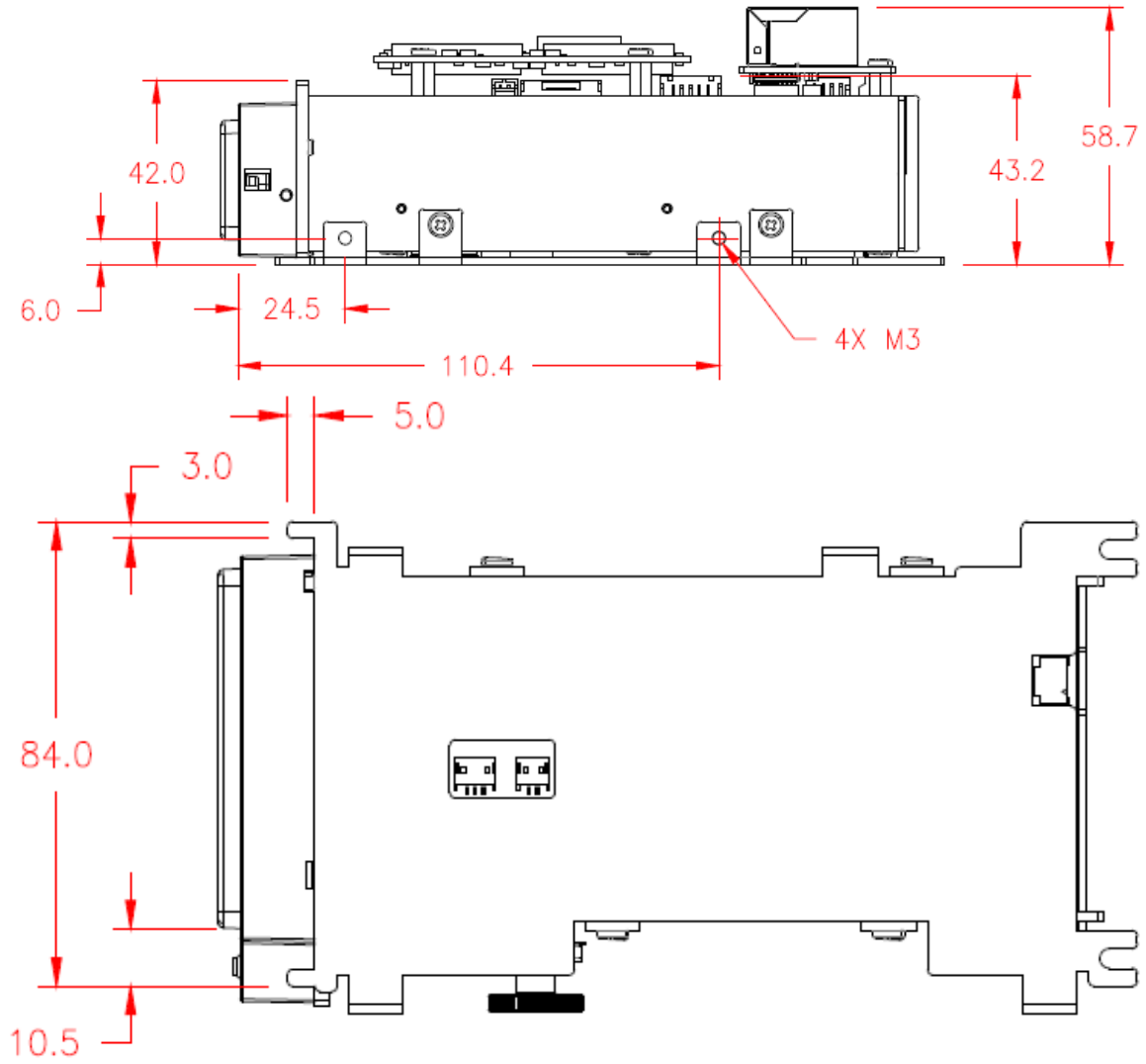

5. NFC Antenna 3-View

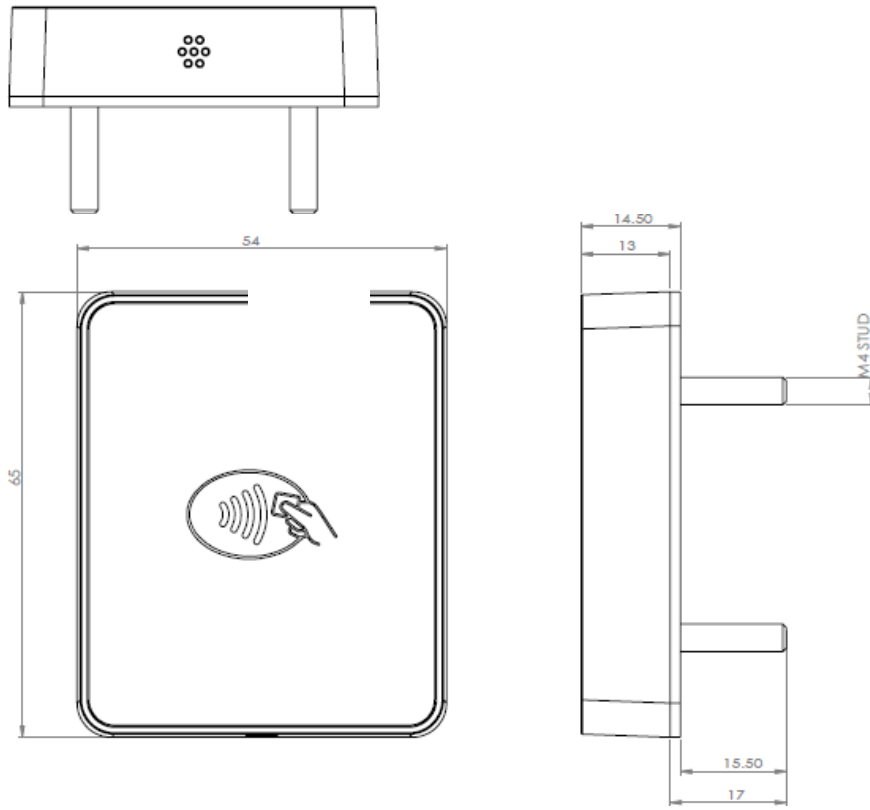

Antenna mounting details:

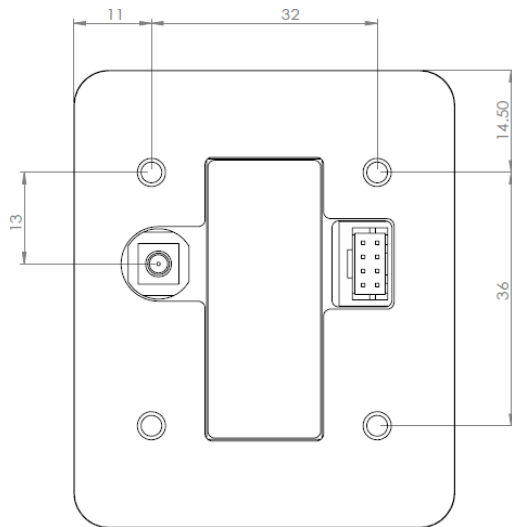

6. VP5300M Installation

This section provides information on how to install the VP5300M in an enclosure.

Note that the unit may be installed edgewise (vertically), or in a horizontal manner. It can also be bolted to or custom-mounted flush with a surface. In the latter case, make sure to allow a 3mm (minimum) cutout clearance around the edge of the metal face flange (assuming the enclosure is metallic) to maintain good NFC performance. **Do not tightly flush-mount the unit to a metal enclosure.** Test NFC performance thoroughly to be sure no interference or signal attenuation occurs.

6.1. Parts List

Verify that you have the following hardware for installing the VP5300M:

- IDM-101: VP5300M; Ethernet, No SAM, JIS; No conformal coating; Production Unit; No custom features.
- (Optional) ViVOpay 5300M NFC Antenna P/N ID-80152002-003. You will need this item and its cable (P/N 80152235-001 or 80152236-001) to use VP5300M's contactless (NFC) capabilities.
- USB cable P/N 80171201-001, or RS-232 cable P/N 80171203-001.
- Power supply P/N **AC0005R-12** with cable 80171204-001.

6.2. Installing the Reader

Refer to the [VP5300M 3-view drawing](#). Verify that power cords can physically reach the unit. Then proceed to:

- Locate, mark, and drill holes for the mounting points of the unit.
- Secure the unit to the enclosure with bolts or screws of appropriate depth. Note that the anti-tamper nubs, located on the unit's left side, must be depressed when the unit is mounted.

6.2.1. Protective Plastic Film

Note that the VP5300M comes with protective plastic film covering printed circuit boards and other sensitive components; keep this protective film on the device during and after installation to ensure it functions as expected.

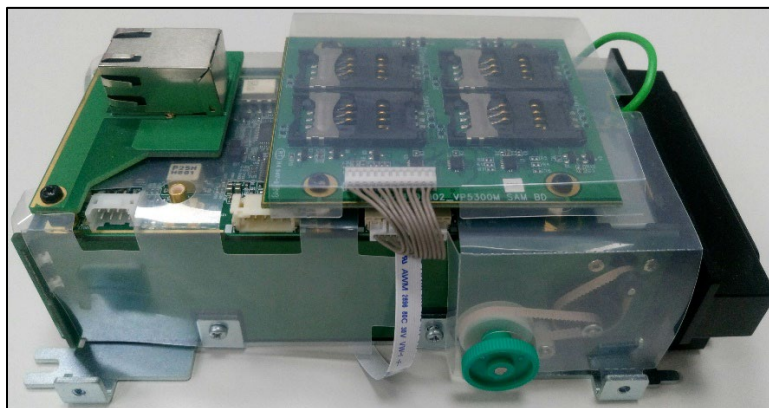

6.3. Mounting the VP5300M External NFC Antenna

Refer to the [VP5300M Antenna 3-view drawing](#). If you are using the VP5300M's contactless capability, you will need to install the optional NFC antenna and its cabling.

Use the following instructions to mount the antenna on the exterior of a kiosk.

Note: It is recommended that you experiment with and verify the orientation of the NFC Antenna before marking and drilling mounting holes, ensuring that the antenna is far enough away from the main body of the VP5300M so that insertion of a "tap card" in the unit's contact-EMV slot doesn't trigger an unwanted NFC interaction.

Important: Mark holes in such a way as to ensure that the ViVOpay NFC Antenna is oriented with the LEDs at the top.

1. Locate and mark the four 4.5 mm (3/16 inch) mounting holes.

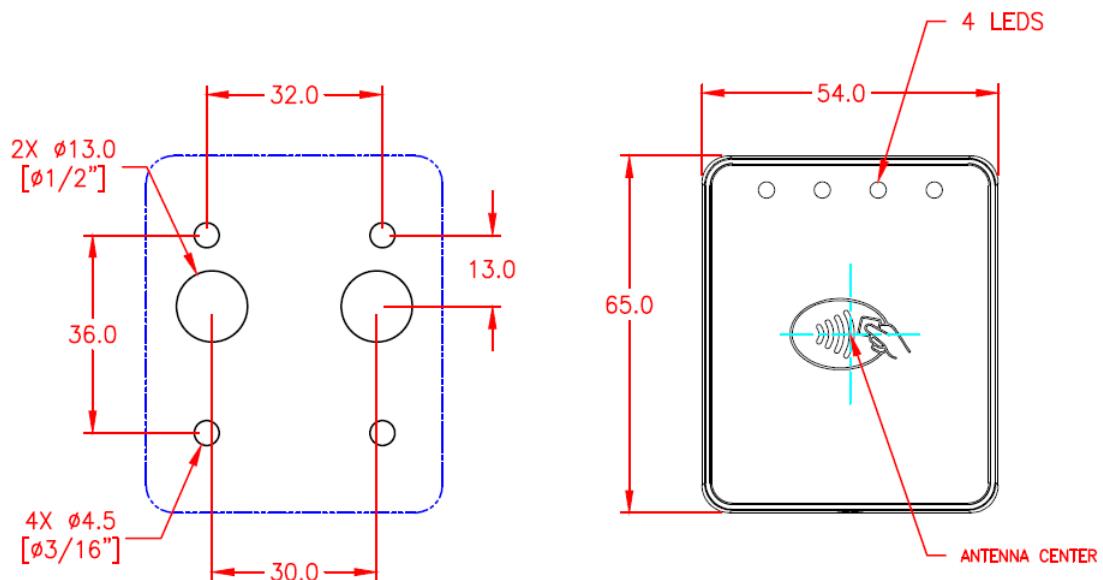

RECOMMENDED CUTOUT FOR MOUNTING

2. Locate and mark two 14.0 mm (0.551 inches) access holes (used for connecting the antenna barrel connector and the LED power and data cable to the unit. Notice that these holes are located off-center toward the top of the unit.
3. Drill the four 4.5 mm (3/16 inch) mounting holes.

4. Drill the two access holes (14.0 mm, 0.551 inch) holes using a 35/64 drill bit.



5. Use the nuts that are supplied with the unit (in plastic bag).
6. Route the end of the cable (80152235-001) with the RJ-45 connector through the matching 14.0 mm (0.551 inch) hole into the kiosk. Make sure that the front of the antenna will be properly oriented (not upside down) on the kiosk before inserting the four screws into the mounting holes.

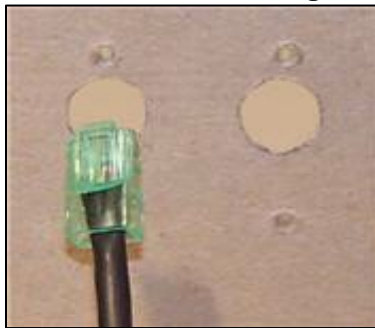

7. Align the four threaded posts with their mounting holes and attach the ViVOPay NFC Antenna to the mounting surface. Make sure that the cable is not pinched, rubbing, or binding.



8. Use the four nuts to secure the ViVOpay NFC Antenna to the surface of the kiosk. Make sure to tighten the nuts securely so that the antenna does not move freely on the outside surface of the kiosk.

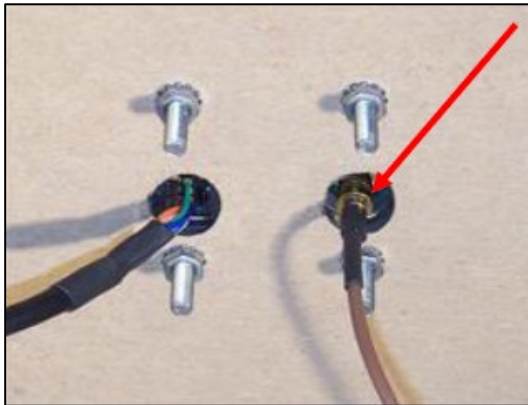

Note: Tighten the nuts to 5-7 in/lbs. for a good weather-tight seal.

9. Attach the end of the cable with the SMB barrel connector through the right 14.0 mm (0.551 inch) hole and secure it to its socket on the back of the antenna. The SMB connector pushes onto the socket.
10. Attach the RJ-45 connector (male) coming from the ViVOpay NFC Antenna to the RJ-45 receptacle (female) on the 80152236-001 cable.

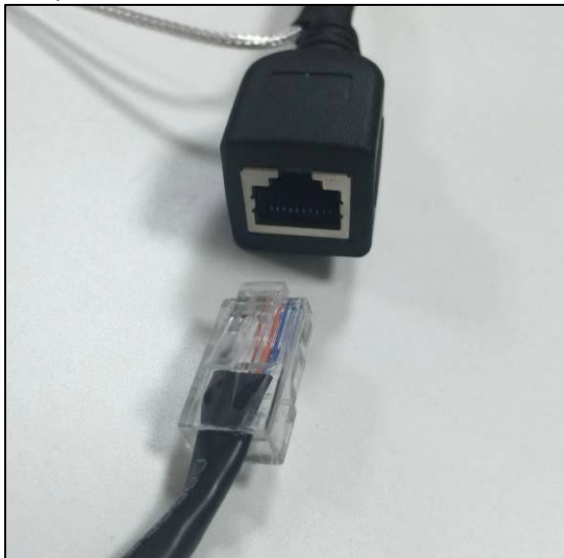

6.3.1. Flush-Mounting the Antenna

The antenna's RF field is sensitive to the proximity of metal. There are three options when flush-mounting the antenna in a metal surface or bezel:

1. Mount with the RF emitting surface of the antenna at least 1cm forward of any metal.
2. Mount with the RF emitting surface of the antenna at least 1cm behind any metal. **Note:** this reduces the antenna's effective range.
3. Mount flush with the metal but allow a minimum of 1cm spacing between the antenna and the metal.

In all three cases, **make sure to test the antenna** mounting before engaging in a production-ready installation.

6.4. VP5300M Connectors

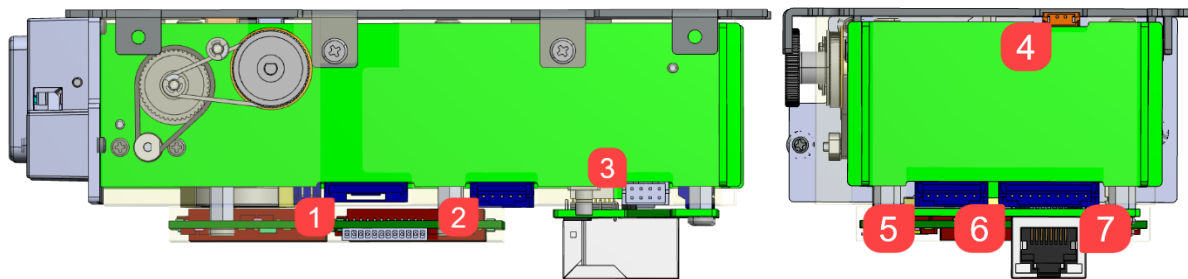

#	Description	Cable
1	SAM slot	Additional SAM slot (optional)
2	USB port	80171201-001, 4-pin USB cable
3	Antenna	80152236-001, connect to NFC antenna (ID-80152002-003)
4	Power	80171204-001, 2-pin power cable, with adaptor AC0005R-12
5	PINPAD	80141220-001, L100 cable
6	RS-232	80171203-001, 9-pin RS-232 cable
7	Ethernet	RJ-45 Ethernet cable (optional)

6.5. Attaching the Cables from the Antenna to the VP5300M

1. Attach the SMB barrel end of the cable (80152236-001) from the antenna to the SMB post of the VP5300M. The connector slides on.
2. Attach the 8-pin end of the cable (80152235-001) from the antenna to the VP5300M.

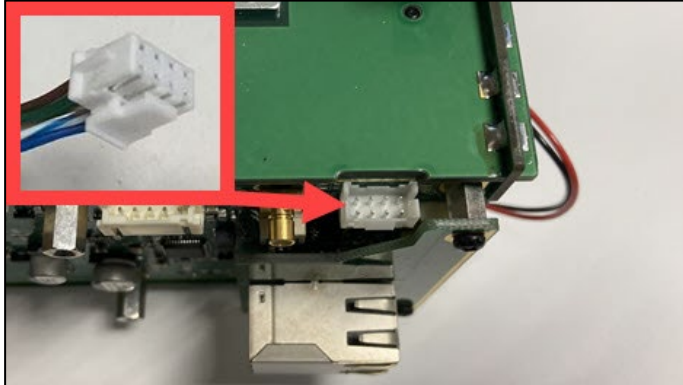

6.6. Connecting to Power

The VP5300M is powered through the power input connector.

1. Connect the 12V DC power supply (P/N AC0005R-12) with cable 80171204-001 to the receptacle on the bottom side of unit.

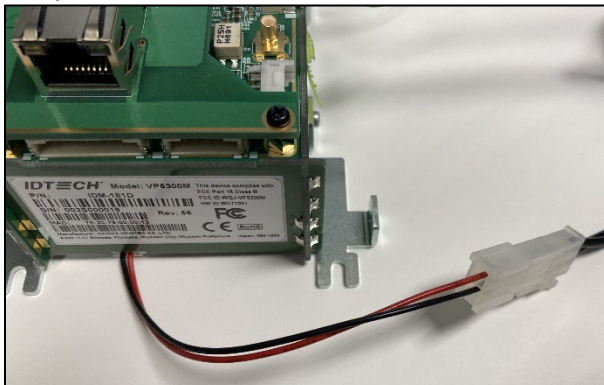

2. Plug the unit in to an AC outlet and verify that the VP5300M lights up.

Note: The VP5300M requires a power supply whether connected by RS-232 or USB.

6.7. Connecting to the Data Port

Use 9-pin JST P/N PHR-9 (or equivalent) for the RS232 connector or 5-pin JST P/N PHR-5 (or equivalent) for the USB connector. See diagrams below for RS-232 or USB, as appropriate.

6.8. VP5300M External Cable Pin Assignments: RS-232

WIRE CONNECTIONS				
P1	COLOR	GAUGE	SIGNAL	J1
2		26	RXD	3
3		26	TXD	5
4		26	DTR	6
5		26	GND	7
6		26	DSR	1
7		26	RTS	2
8		26	CTS	4
SHELL	DRAIN	26	CASE GND	9

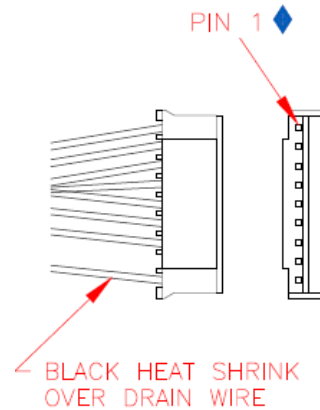

6.9. VP5300M External Cable Pin Assignments: USB

WIRE CONNECTIONS				
P1	COLOR	GAUGE	SIGNAL	J1
1	--	--	N/C	--
2	WHITE	28	DATA-	3
3	GREEN	28	DATA+	2
4	BLACK	26	GND	4
SHELL	DRAIN	26	CASE GND	5

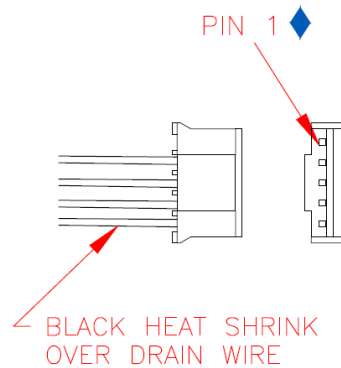

6.10. Installation Notes

- The VP5300M is designed to be mounted on a metal surface and in reasonably close proximity to any internal motors and electrical devices that may be operating inside the kiosk. However, the unit (like all NFC/RFID devices) is susceptible to RF and electromagnetic interference.

NOTE: DO NOT mount the VP5300M near (within 3 or 4 feet of) large electric motors, computer UPS systems, microwave transmitters, anti-theft devices, radio transmitters, routers, or similar electronics.

- Close proximity of metal to antenna's the RF-emitting end can greatly reduce the antenna's range.
- Tie all cables neatly with nylon cable-ties and route them so that they are inaccessible and invisible to customers. Label the cable ends as "host," "ViVOPay," and "power" to simplify connection testing or component replacement, particularly when untrained individuals might be involved.
- Test the installation using a test card to perform an end-to-end transaction (the same as an actual purchase). The NFC antenna front panel's light should illuminate. Even if the transaction is declined (as it should be with a test card), it will prove connectivity all the way through the system. If possible, the store manager or some other responsible party should test each VP5300M on a regular basis (perhaps at the start of each day or at least once per week) with a test card to ensure continued operation and functionality. If the unit is manually rebooted, it is important to test the contactless reader portion as soon as possible afterwards to verify continued communication. Note that the reader automatically reboots once every 24 hours on its own, and performs a firmware self-check at that time, to meet PCI requirements.

7. LED Management

The VP5300M has three LED indicators:

- One user-interface LED on the reader's front bezel
- Four LEDs on the RF antenna on the front of the unit
- One diagnostic LED on the back of the device

7.1. Front LED Status

- The LED turns green when the unit is idle.
- LED handling for MagStripe card operation is as follows:

State	LED1	Buzzer	Indicated State
1	Off	Off	No external power.
2	Solid Green	Off	Idle or a non-MagStripe card was inserted.
3	Off ->Solid Green->Off	One short beep	Successfully read MagStripe card.
4	Off ->Solid Red->Off	Off	Failed to read MagStripe card.

7.2. RF LED Status

- The LED on the VP5300M's external antenna shows the transaction status for smart and contactless cards.
- The LEDs can be off, solid, or flashing slow or fast, depending on the indicated status.

State	LED1	LED2	LED3	LED4	Buzzer	Indicated State
1	Off	Off	Off	Off	Off	RF antenna is not connected to the unit.
2	Slow Flashing	Off	Off	Off	Off	Unit is ready.
3	Solid	Off	Off	Off	Off	Unit is waiting to read cards.
4	Fast Flashing	Off	Off	Off	Off	Powering on the smart card slot and starting smart card operation.
5	Solid	Solid	Solid	Solid	One long beep	Successful contactless card transaction.
6	Off	Off	Off	Off	Three short beeps	Failed contactless card transaction.
7	Off	Off	Off	Off	Two short beeps	Declined contactless card transaction.
8	Solid	Solid	Solid	Solid	One short beep	Successful MagStripe card read.

7.3. Diagnostic LED Status

- The LED on the *back* of the VP5300M is used for diagnostic purposes.
- The LED can be off, solid, or flashing (one second on and one second off), depending on the indicated status.

State	Diagnostic LED	Buzzer	Indicating	Service Action
1	Off	Off	No external power.	Check the power cable and power supply.
2			Power is on, but firmware doesn't run.	Dismount the device and send it back to the manufacturer.
3	Flashing Amber		Power on. Missing transaction keys.	Download the required key.
4	Flashing Green		Power on. Missing transaction keys.	Download the required key.
5	Solid Green		Unit is ready.	Host can send commands to the reader.
4	Solid Red	Intermittent beep	Unit is tampered.	Unmount the device and send it back to the manufacturer.

8. Warped Card Support

VP5300M readers support warped cards of "H" dimension (below) within 2mm for card length direction or 1mm for card width direction.



Note: VP5300M readers do not currently support metal cards.

9. Using the VP5300M to Make a Contactless Purchase

9.1. Presenting Proximity Cards or NFC Phones

The VP5300M allows for credit/debit card purchases using Contactless technology when the optional NFC antenna is installed.

Present the card or phone in close proximity to the front portion of the antenna module. Present the card or phone so that maximum surface area is parallel to the antenna module.



The antenna should beep and all four green LEDs should illuminate briefly to indicate a successful test.

This tests the antenna's ability to read the Contactless test card. An unsuccessful test produces no reaction from the reader. If you use a test card and the antenna is attached to the VP5300M, a dummy transaction can be tested. The transaction will not be authorized and return a response but will at least test for end-to-end connectivity.

10. Maintenance

Clean the VP5300M on a weekly basis with a card reader cleaning card to clean the device's magnetic heads and rollers. Clean the surface of the card insertion bezel with a lint-free cloth.

10.1. Cleaning the VP5300M

Dirt accumulated on the VP5300M's magnetic heads, rollers, or the ICC connector's contact pins will result in read errors of magnetic and ICC cards or card jamming.

Clean VP5300M readers on a weekly basis or a defined period using a cleaning card and cleaning liquid to clean the magnetic heads, rollers, and ICC contact pins. Clean the card insertion bezel surface with a lint-free cloth.

10.1.1. Cleaning the Magnetic Heads

To clean the reader's magnetic heads and ICC contact pins (automatically cleaned in "cleaning mode"):

1. Apply cleaning liquid (IPA, Isopropyl alcohol) to the locations on the cleaning card shown below:

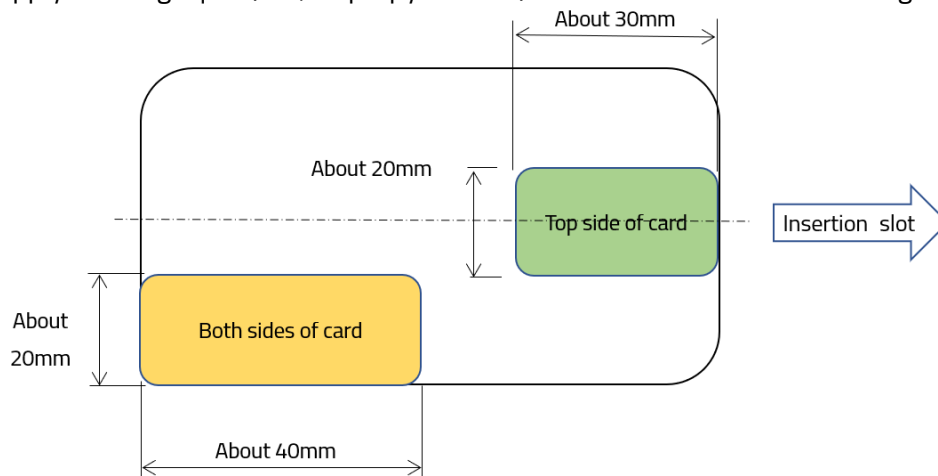

2. Confirm the VP5300M is powered on and send the "cleaning command" from the host device to the reader to place the VP5300M in "cleaning mode".
3. Insert the cleaning card to the bezel opening; the reader transports the card inside to start the cleaning process automatically.

After the VP5300 ejects the cleaning card, the process is complete.

Note: If the card is heavily contaminated after one round of cleaning, repeat steps one through three to clean the reader again.

10.1.2. Cleaning the Transportation Rollers

Follow the steps below to clean the transportation rollers. Note: use the manual knob to turn the roller for cleaning.

1. Turn off or cut off power to the VP5300M.
2. Apply cleaning liquid (IPA) to the locations on the cleaning card shown below.

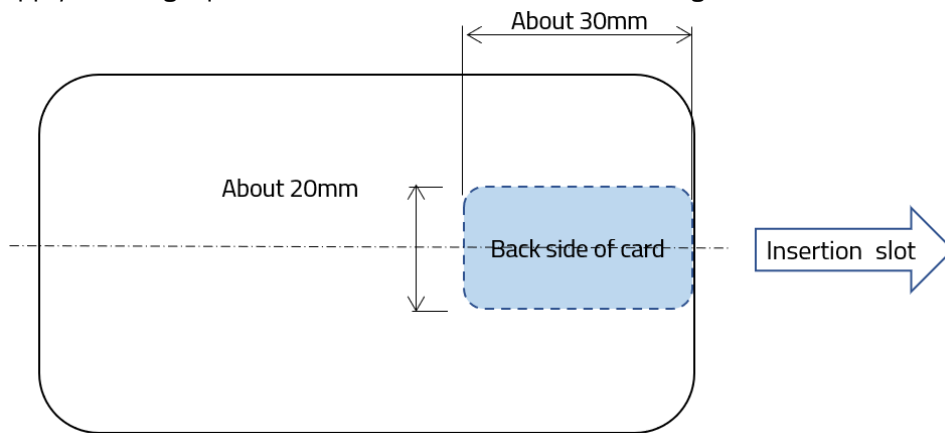

3. Use a thin rod to move the lock lever in the direction shown below to unlock the gate. Insert the cleaning card when the gate is unlocked.

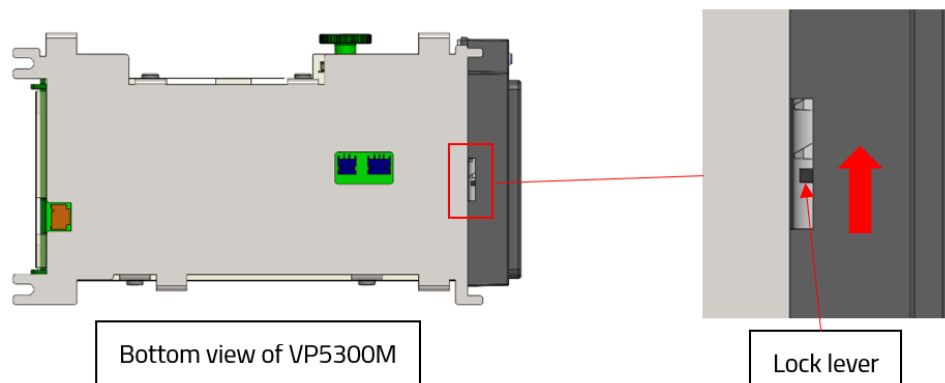

4. Holding the cleaning card by your fingers, when there is only about 20mm of the card left outside of reader, turn the manual knob five times in the direction shown below. **Hold the card firmly to prevent the card being pulled in when turning the manual knob.** If the card is pulled in, turn the manual knob in reverse to remove the card.

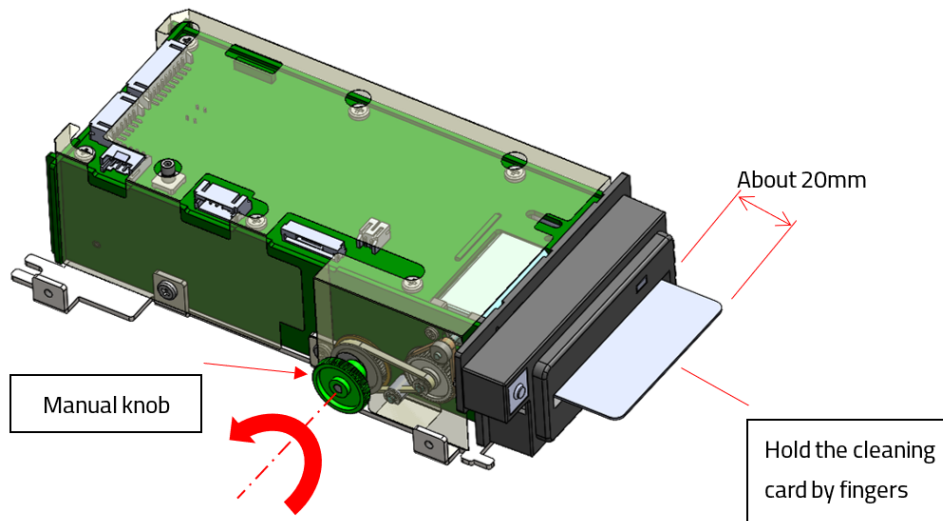

5. Remove the cleaning card to finish the cleaning process.

Note: After roller cleaning, wait two to three minutes for the IPA cleaning liquid to dry before using the VP5300M.

If the cleaning card is heavily contaminated after use, use the opposite or reverse side for the next cleaning.

10.1.3. Cleaning Guidelines

- Clean VP5300M readers after every 1000 transactions.
- Depending on the installation environment or user cases, adjust the frequency of cleaning process as needed.

Caution

- The cleaning solution is flammable; make sure to firmly seal it with the cap.
- Keep cleaning solution away from direct sunlight, high temperature, or high moisture.
- Keep cleaning solution out of reach of children.
- In case of spraying cleaning solution into eyes, flush eyes with water immediately.
- Keep cleaning solution away from flames.

11. Pairing with PIN Pad

The VP5300M is designed to be paired with ID TECH's SmartPIN L100 or L80 keypads to create a full chip- and-PIN solution. Follow the pairing procedures below to use the L100 or L80 with the VP5300M.

First, set up the L100 or L80 for paired operation by specifying two user passwords; then set up the VP5300M; and then, finally, pair the two devices.

11.1. Setting up the L100 or L80

1. Cycle the power to the insert reader (unplug the power from the USB cable and plug it back in).
2. After plugging the power into the USB cable again, you have only 2 seconds to begin entering the special pairing command on the keypad (otherwise, you'll need to cycle the power again). To get into the special menu, press the following keys in this order:

SmartPIN L100	SmartPIN L80
• Cancel	• Cancel
• Clear	• 5
• Enter	• Enter
• Blank	• 0
• Clear	• 5
• Enter	• Enter

3. The L100 or L80 will start beeping to indicate that the user passwords are not yet set and the LCD screen will prompt to enter a password.
4. Enter default Password A: **12345678**. Make sure the device beeps after each button is pressed to register the input. After correctly entering the default Password A, the device beeps twice.
5. Enter a new user-created Password 1 to replace Password A. The new Password 1 must be eight digits (for example: 11111111). After entering the new Password 1, the device beeps twice to confirm the input. Make a note of the new Password 1 in your records.
6. The device will prompt you to reenter the password. Enter the new Password 1 again to confirm it. After entering the new Password 1 a second time, the device beeps twice to confirm successful verification.
7. Next, enter default Password B: **87654321**. Make sure the device beeps after each button is pressed to register the input. After entering the default Password B correctly, the device beeps twice.
8. Enter a new user-generated Password 2 to replace Password B. The new Password 2 must be 8 digits and must be different from Password 1 (for example: 22222222). After entering the new Password 2, the device beeps twice to confirm successful verification. Make a note of the new Password 2 in your records.

9. The device prompts you to reenter the password. Enter the new Password 2 again to confirm it. After entering the new Password 2 for a second time, the device beeps twice to confirm the input. The SmartPIN L100 or L80 Removal Detection passwords are now set.
10. The next menu on the L100 or L80 screen has the option to **Enable**. Choose the top option (scroll up or down using the * and # keys) and press the green **Enter** key. The device displays an "Activate Success" prompt to indicate success.

11.2. Setting up the VP5300M

To set up the VP5300M for chip-and-PIN operation, you will need to configure the unit to operate in Configuration 3C. Out of the box, the VP5300M uses the **4C configuration**, which indicates the reader performs EMV transactions without a PIN pad.

Switching the unit to a 3C configuration can be done easily with ID TECH's free USDK Demo program on any Windows SDK computer. Download the free demo program from the [VP5300M product section of the ID TECH Knowledge Base](#) (look for the USDK_DEMO zip file). No registration is required.

1. Launch the USDK Demo program and plug the VP5300M into the USB port of your computer. Verify that the VP5300M is shown as selected on the left side of the window:

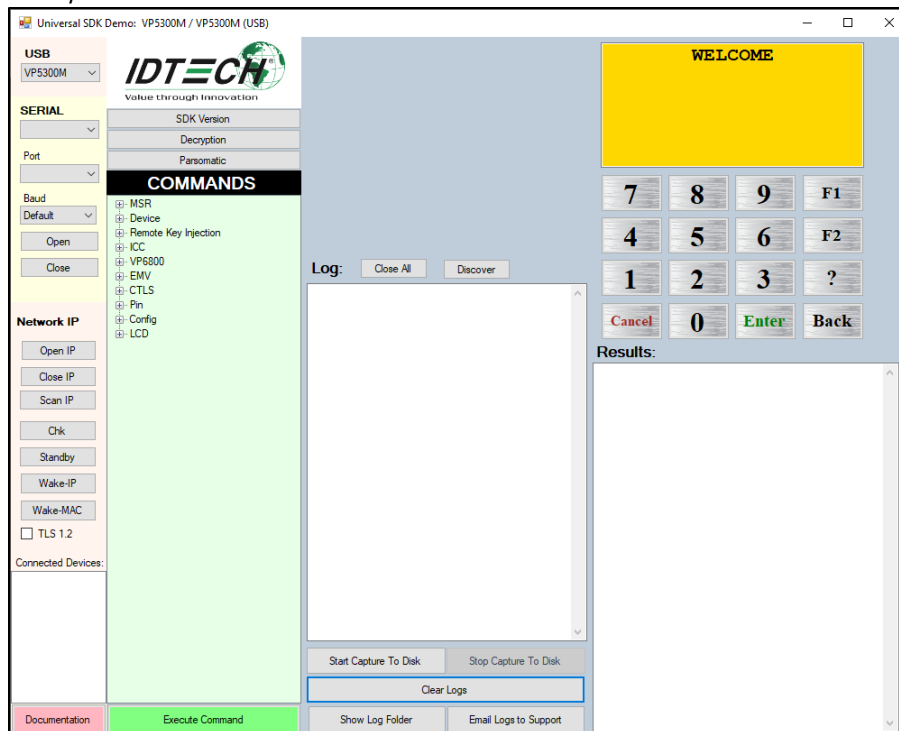

- Verify that the firmware version of your VP5300M is higher than v72. Select the **Device** command tree, select the **Firmware Version** command, and click **Execute Command**. If the firmware version is lower, please contact your ID TECH sales rep for more instructions.

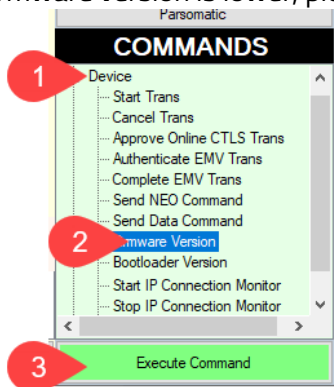

- Open **Commands > EMV > Terminal Config** to expose command names. Select the **Set Config #3** command and click the **Execute Command** button. This configures the VP5300M reader to accept 3C configuration settings.

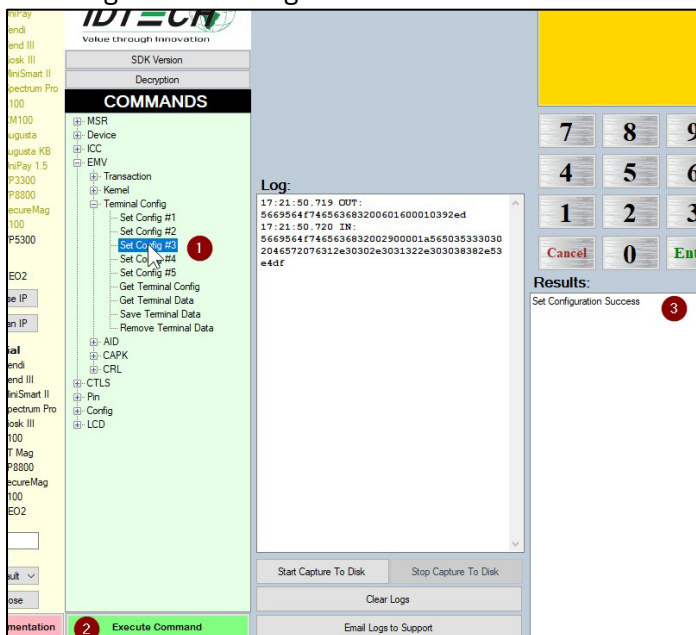

- Find the **Save Terminal Data** command (see below). When you select it, the upper portion of the center panel will change appearance and show a CONFIG dropdown menu along with a TLV text area. Select **3C** from the dropdown (leave the TLV area as it is), then click **Execute Command**.

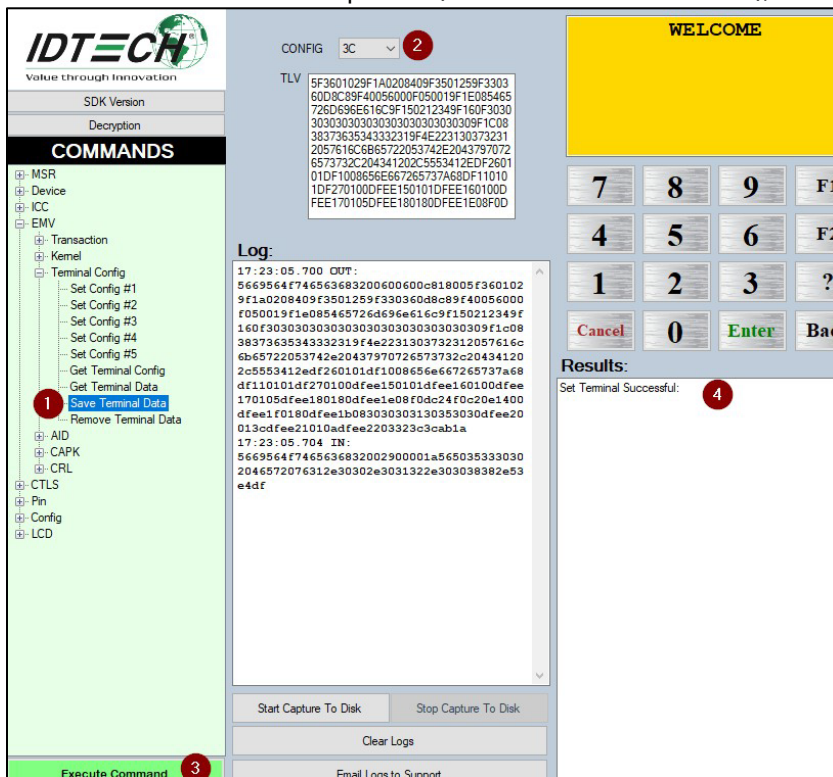

11.3. Pair the Devices

1. Open **Device > Send NEO Command**. Enter **63** for Cmd and **01** for Sub in the text boxes at the top of the center panel (as shown below). This command pairs the readers.

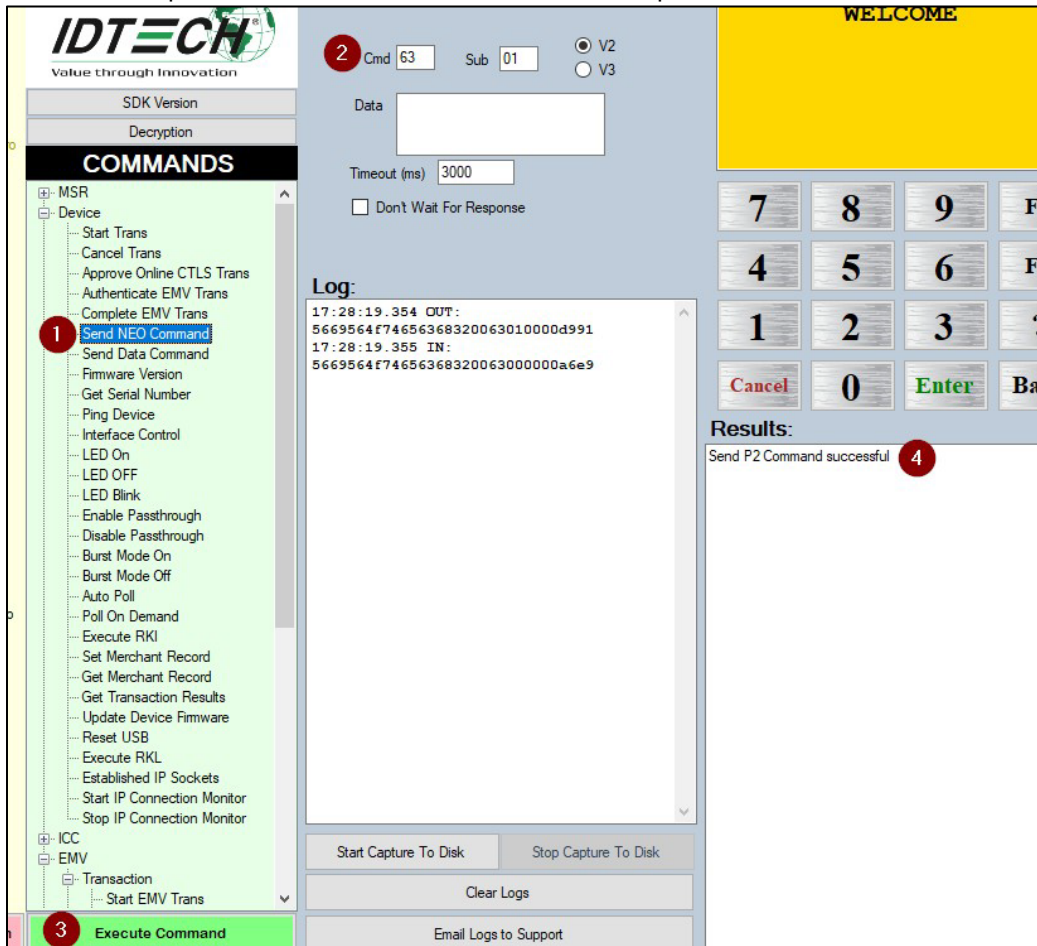

- The VP5300M is now fully configured to do PIN-based transactions (if the presented credit card supports them). Verify that the VP5300M's front removal detection switch is firmly pressed down. The pressure switch is located on the front bezel's left side and looks like a small button on a white rubber square. If the unit is not mounted in a kiosk or other fixture, temporarily engage the pressure switch by attaching a binder clip to the left side of the flange:

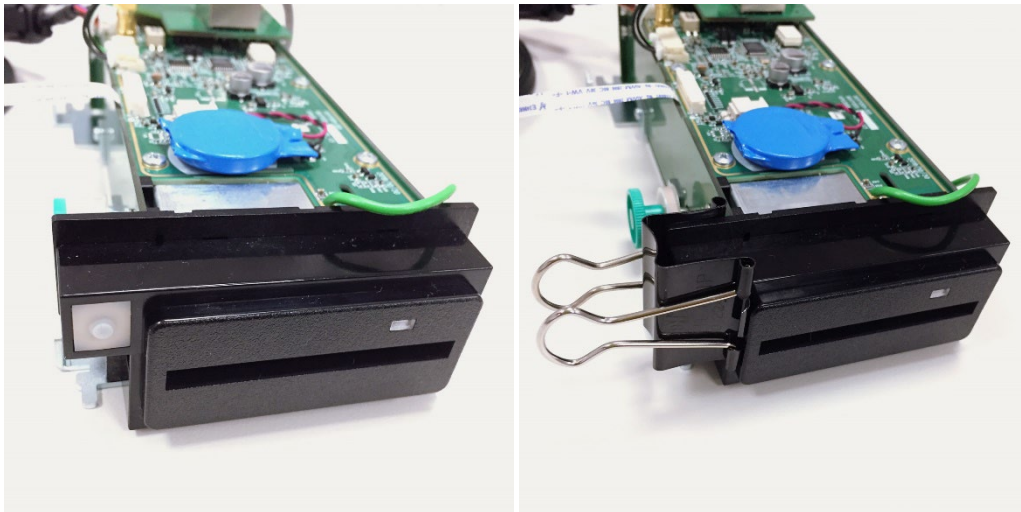

- Next, return to the L100 or L80 and power-cycle the PIN pad. You have only 2 seconds to start entering the special pairing command on the keypad. To get into the special menu, press:

SmartPIN L100	SmartPIN L80
<ul style="list-style-type: none"> • Cancel • Clear • Enter 	<ul style="list-style-type: none"> • Cancel • 5 • Enter
<ul style="list-style-type: none"> • Blank • Clear • Enter 	<ul style="list-style-type: none"> • 0 • 5 • Enter

11.3.1. Enabling SmartPIN L100 Devices

1. The L100 or L80 front display now shows two options: **Enable PinPad**, and **Enable CR** (in this case, CR means "card reader"). Use the **#** and ***** keys to scroll up or down. Select **Enable CR** and press **Enter**.



2. Setup is now complete. Execute the **Start EMV Transaction** command in the USDK Demo, or start a transaction from your own software, and then insert a PIN debit card. After the prompt for PIN comes up, the unit should display "ENTER PIN:" as shown below:

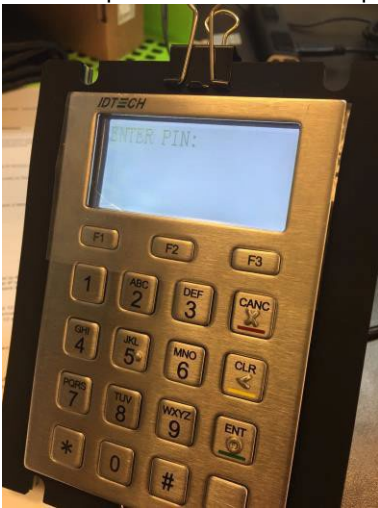

Note: The test card must be a PIN-capable EMV card. We recommend using the appropriate test card from a deck of test cards.

11.3.2. Enabling SmartPIN L80 Devices

1. The L80 front display now shows the **Enable CR** option (in this case, CR means "card reader"). Press **Enter**.

Setup is now complete. Execute the **Start EMV Transaction** command in the USDK Demo, or start a transaction from your own software, and then insert a PIN debit card. After the prompt for PIN comes up, the unit should display "ENTER PIN:".

Note: The test card must be a PIN-capable EMV card. We recommend using the appropriate test card from a deck of test cards.

11.4. L100 Removal Detection and Paired Readers

The SmartPIN L100 comes equipped with a removal detection sensor. For VP5300M readers, triggering the L100's removal sensor disables PIN functions: the reader paired to the L100 will NOT perform PIN transactions. However, transactions not requiring a PIN are unaffected.

12. RF Interference

Q. Why do I need to know about RF interference?

A. Contactless payment devices use radio frequency technology to send card data to a contactless terminal reader.

Q. How can RF interference affect contactless payment?

A. Radio frequency interference can cause data errors. If RF interference is present, contactless payment devices may operate intermittently or inconsistently.

Q. Where does RF interference come from?

A. Radio frequency interference (RFI) can originate from a wide number of sources at the point-of-sale (POS). Some examples of sources of RF energy and RF interference include:

- AM/FM radio and TV transmitters
- 2-way radios and pagers
- Mobile telephones
- Power lines and transformers
- Large electric motors
- Medical equipment
- Microwaves
- Electromechanical switches
- Wireless routers

Q. What should I do if I suspect RF interference exists in my environment?

A. Begin by inspecting your environment for possible sources of RF interference.

Q. Do equipment manufacturers test their devices for RF interference?

A. Yes. Electronic equipment is tested for RFI sensitivity by the manufacturers. These tests are performed in a controlled laboratory environment and will often not replicate the types of situations that would be encountered in your own point-of-sale (POS) environment.

Q. What RF levels will impact RF operations?

A. Factors that can cause RF interference vary case-by-case. There are no set rules defining a single RF level that will cause RFI. RFI depends on the sensitivity of the equipment under consideration, or how low an interpreting signal can be in the presence of the equipment and cause problems.

Equipment can be particularly sensitive to very low signal levels of one frequency and yet be quite immune to high signal levels of another frequency; frequency is an important factor. Some electronic system components are internally shielded and have a very high immunity to interference; but generally, most equipment has not been so engineered.

13. Updating VP5300M Firmware

The steps below describe the process for updating VP5300M firmware via the Universal SDK Demo. ID TECH strongly recommends integrating firmware update commands from our Universal SDK into applications.

Note: Before you begin, contact your ID TECH representative to receive the most recent VP5300M firmware. Download the ZIP file and extract it to your computer.

1. Connect the VP5300M to your PC via either USB or serial port.
2. Download and install the latest [USDK Demo](#) from the ID TECH Knowledge Base (if you cannot access the link, please [contact support](#)).
3. Open the USDK Demo app from the Windows Start menu.

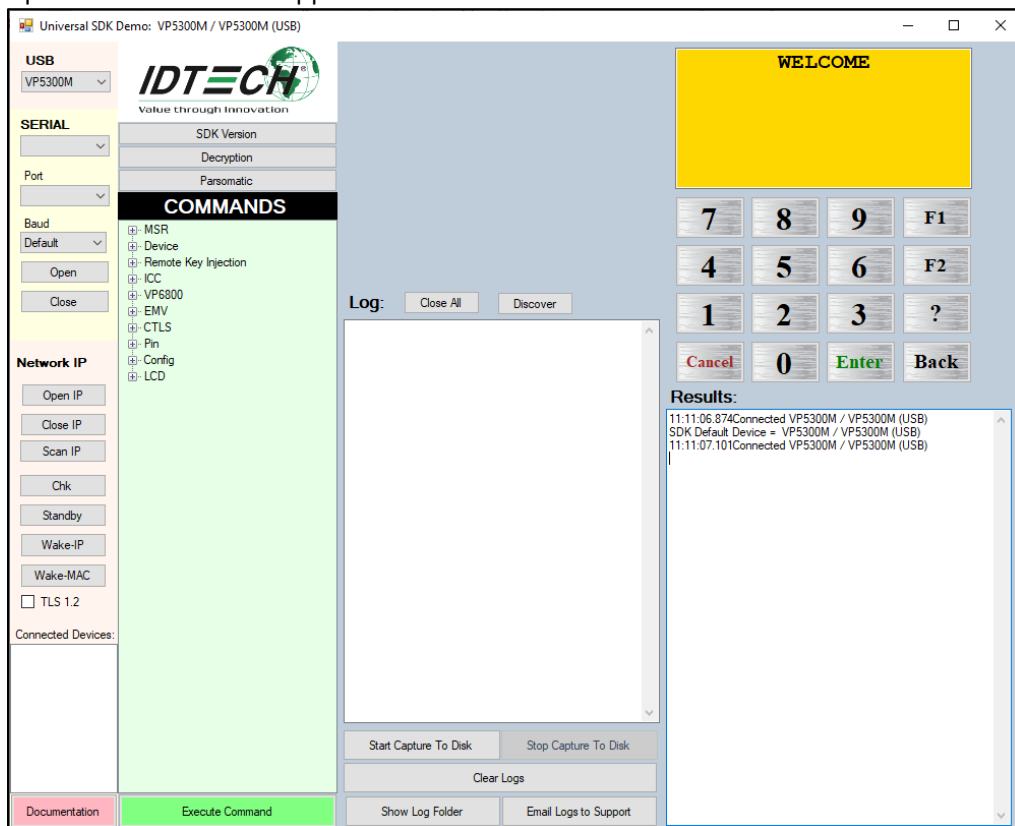

4. Under **Device**, select **Update Device K81 Firmware**, then click **Execute Command**.

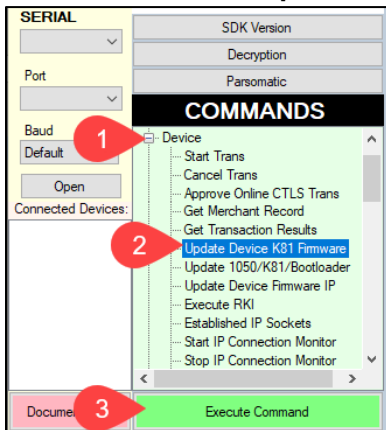

5. Navigate to and select the VP5300M firmware you downloaded earlier and click **Open**.
 6. The VP5300M will reboot and enter the bootloader, at which point the USDK demo begins updating the device.

Note: It may take several minutes to complete the firmware update.

7. When the firmware update completes, the VP5300M will reboot again and the USDK demo will prompt **Firmware Update Successful**.

```

Results:
Sent block 100 of 100 Applying Firmware Update....
SDK Default Device = Device Not Connected
SDK Default Device = VP5300M / VP5300M (USB)
10:52:43.520Connected VP5300M / VP5300M (USB)
10:52:48.097Disconnected Device Not Connected
10:52:48.104Connected VP5300M / VP5300M (USB)
SDK Default Device = Device Not Connected
10:52:48.284Connected VP5300M / VP5300M (USB)
SDK Default Device = VP5300M / VP5300M (USB)
Firmware Update Successful
  
```

14. Troubleshooting

The VP5300M reader is designed to be reliable and easy to troubleshoot. The components that may require troubleshooting include the power module (if applicable), the reader, and the serial cable.

If you are unable to resolve the problem, please contact support@idtechproducts.com (sending an e-mail to this address will automatically open a support ticket).

Symptom	Possible Cause	Remedy
General Issues		
Reader does not appear to be powered on (no LEDs are lit).	<ul style="list-style-type: none"> • Reader not powered on or incorrect voltage. • Improper use of internal power supply provided by the kiosk. 	<ul style="list-style-type: none"> • Check cable connections. • Verify that power is on and correct voltage and current are present. • Make sure that the correct pins are utilized. • Make sure that the power provided is within the specified range of the reader. • Make sure that the correct polarity is observed. • For more information, refer to the Input Voltage under the Electrical specification section. • Replace the device with a known-good device to verify that the power supply and wiring in the installation are sound.
Reading Cards/Phones		
LED is lit, but beeper is not audible when card/fob presented.	<ul style="list-style-type: none"> • Card/fob/phone not properly presented. • RF interference. • Unsupported card used. • Wrong firmware (contact your local support representative). 	<ul style="list-style-type: none"> • Present card/fob/phone closer to the antenna, and ensure it is parallel to the face of the reader. • Verify that the card/fob/phone is valid/current. • Verify that metal is not interfering with the antenna. • Test with "ViVOcard Contactless Test Card" part number 241-0015-03 Rev A. • Try a different card/fob. • Check to see if card/fob is damaged. • Verify that correct firmware is loaded on reader (local support representative only). • Power cable plug is fully inserted. • Replace the unit.
Some cards/fobs read,	<ul style="list-style-type: none"> • Possible bad card/fob. 	<ul style="list-style-type: none"> • Check to see if card/fob is damaged.

Symptom	Possible Cause	Remedy
but not all.	<ul style="list-style-type: none"> • Unsupported card used. • Wrong firmware (contact your local support representative). 	<ul style="list-style-type: none"> • Verify that correct firmware is loaded on reader (local support representative only). • Card readers must contain the latest versions of card-brand public certificates (CAPKs). If a CAPK is out of date, one particular kind of card may no longer be usable. Update the CAPK.
Communication to Kiosk		
No data is received, or data is garbled.	<ul style="list-style-type: none"> • Faulty or incorrect cable connections. 	<ul style="list-style-type: none"> • Check that the cable connection is secure and in the correct port on the unit.
Load Firmware		
Firmware loading software indicates "open RS-232 failed"	Device is not completely connected to PC, or other software is using the serial interface.	<ul style="list-style-type: none"> • Check the cable connection • Close other software which might be using the same serial interface.
Firmware loading software indicates "Load firmware failed."	Device is not well connected to PCs.	<ul style="list-style-type: none"> • Check the cable connections.
Firmware loading software indicates "Send Command failed."	Bootloader firmware in device is destroyed.	<ul style="list-style-type: none"> • Contact your support representative to reload manufacture's firmware.

15. Tamper and Failed Self-Check Indicators

The VP5300M displays the following indicators when it has been tampered or has any of the other following internal issues, such as an expired certificate, missing key, or similar fault discovered during a self-check.

The VP5300M's diagnostic LED is located near the back of the reader, below the ethernet port PCB.

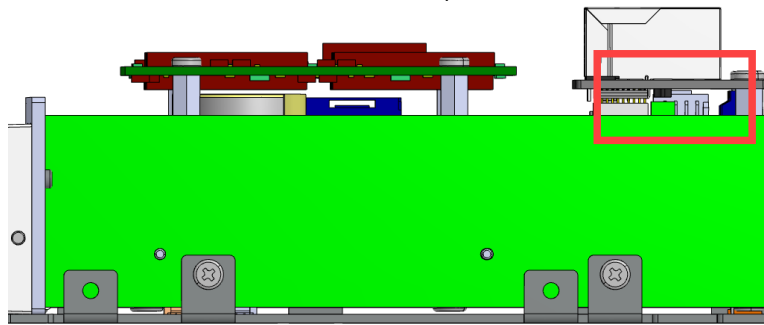

Indicator	Tampered Status	Other Issue Status
Front LED	Off	All LEDs off
Back Diagnostic LED	Solid red	See below
SmartPIN L100 or L80 LCD	TAMPERED	See below
Buzzer	Alarm tone	Alarm tone

When paired to a SmartPIN L100 or L80, the VP5300M can indicate the following issues in the event of a failed self-check:

- "CERT FAILED" indicates the battery is drained or certificate expired.
- "FW/BL FAILED" indicates the bin and sign do not match.
- "CLL2" indicates the Contactless kernel self-check failed.
- "KEYS FAILED" if no injection key happened.
- "WHITELIST FAILED" indicates that CL or MSR whitelist verification failed.

16. FCC warning statement

This device complies with Part 15 of the FCC Rules. Operation is subject to the following two conditions: (1) this device may not cause harmful interference, and (2) this device must accept any interference received, including interference that may cause undesired operation.

The user manual for an intentional or unintentional radiator shall caution the user that changes or modifications not expressly approved by the party responsible for compliance could void the user's authority to operate the equipment.

Note: The grantee is not responsible for any changes or modifications not expressly approved by the party responsible for compliance. Such modifications could void the user's authority to operate the equipment.

Note: This equipment has been tested and found to comply with the limits for a Class B digital device, pursuant to part 15 of the FCC Rules. These limits are designed to provide reasonable protection against harmful interference in a residential installation. This equipment generates uses and can radiate radio frequency energy and, if not installed and used in accordance with the instructions, may cause harmful interference to radio communications. However, there is no guarantee that interference will not occur in a particular installation. If this equipment does cause harmful interference to radio or television reception, which can be determined by turning the equipment off and on, the user is encouraged to try to correct the interference by one or more of the following measures:

- Reorient or relocate the receiving antenna.
- Increase the separation between the equipment and the receiver.
- Connect the equipment into an outlet on a circuit different from that to which the receiver is connected.
- Consult the dealer or an experienced radio/TV technician for help.

This device complies with FCC RF radiation exposure limits set forth for an uncontrolled environment. The antenna(s) used for this transmitter must not be co-located or operating in conjunction with any other antenna or transmitter and must be installed to provide a separation distance of at least 20cm from all persons.

17. IC Compliance Warning



This device contains licence-exempt transmitter(s)/receiver(s) that comply with Innovation, Science and Economic Development Canada's licence-exempt RSS(s). Operation is subject to the following two conditions:

1. This device may not cause interference, and
2. This device must accept any interference, including interference that may cause undesired operation of the device.

L'émetteur/récepteur exempt de licence contenu dans le présent appareil est conforme aux CNR d'Innovation, Sciences et Développement économique Canada applicables aux appareils radio exempts de licence. L'exploitation est autorisée aux deux conditions suivantes :

1. l'appareil ne doit pas produire de brouillage, et, and
2. l'utilisateur de l'appareil doit accepter tout brouillage radioélectrique subi, même si le brouillage est susceptible d'en compromettre le fonctionnement.

18. Cautions and Warnings

	<p>Warning: Avoid close proximity to radio transmitters which may reduce the capability of the reader.</p> <p>Avertissement : Évitez la proximité d'émetteurs radio, ce qui peut réduire la performance du lecteur.</p>
	<p>Caution: Do not drop the device.</p> <p>Attention : Ne pas laisser tomber le lecteur.</p>
	<p>Caution: Electrostatic sensitive device. Use caution in handling, in high ESD conditions.</p> <p>Attention : Le lecteur est sensible aux décharges électrostatiques. Manipulez le lecteur avec précaution dans une situation d'électricité statique élevée.</p>