



Augusta and Augusta S USER MANUAL

**80145503-001 Rev. 0
15 January, 2021**

ID TECH
10721 Walker Street, Cypress, CA 90630
Voice: (714) 761-6368 Fax: (714) 761-8880
<http://www.idtechproducts.com>

© 2021 ID Technologies, Inc. All rights reserved

ID TECH
10721 Walker Street
Cypress, CA 90630
Voice: (714) 761-6368 Fax: (714) 761-8880

Visit us at <http://www.idtechproducts.com>

The information contained herein is provided to the user as a convenience. While every effort has been made to ensure accuracy, ID TECH is not responsible for damages that might occur because of errors or omissions, including any loss of profit or other commercial damage, nor for any infringements or patents or other rights of third parties that may result from its use. The specifications described herein were current at the time of publication but are subject to change at any time without prior notice.

LIMITED WARRANTY

ID TECH warrants to the original purchaser for a period of 12 months from the date of invoice that this product is in good working order and free from defects in material and workmanship under normal use and service. ID TECH's obligation under this warranty is limited to, at its option, replacing, repairing, or giving credit for any product that returned to the factory of origin with the warranty period and with transportation charges and insurance prepaid, and which is, after examination, disclosed to ID TECH's satisfaction to be defective. The expense of removal and reinstallation of any item or items of equipment is not included in this warranty. No person, firm, or corporation is authorized to assume for ID TECH any other liabilities in connection with the sales of any product. In no event shall ID TECH be liable for any special, incidental or consequential damages to purchaser or any third party caused by any defective item of equipment, whether that defect is warranted against or not. Purchaser's sole and exclusive remedy for defective equipment, which does not conform to the requirements of sales, is to have such equipment replaced or repaired by ID TECH. For limited warranty service during the warranty period, please contact ID TECH to obtain a Return Material Authorization (RMA) number & instructions for returning the product.

THIS WARRANTY IS IN LIEU OF ALL OTHER WARRANTIES OF MERCHANTABILITY OR FITNESS FOR PARTICULAR PURPOSE. THERE ARE NO OTHER WARRANTIES OR GUARANTEES, EXPRESS OR IMPLIED, OTHER THAN THOSE HEREIN STATED. THIS PRODUCT IS SOLD AS IS. IN NO EVENT SHALL ID TECH BE LIABLE FOR CLAIMS BASED UPON BREACH OF EXPRESS OR IMPLIED WARRANTY OF NEGLIGENCE OF ANY OTHER DAMAGES WHETHER DIRECT, IMMEDIATE, FORESEEABLE, CONSEQUENTIAL OR SPECIAL OR FOR ANY EXPENSE INCURRED BY REASON OF THE USE OR MISUSE, SALE OR FABRICATIONS OF PRODUCTS WHICH DO NOT CONFORM TO THE TERMS AND CONDITIONS OF THE CONTRACT.

ID TECH and Value through Innovation are trademarks of International Technologies & Systems Corporation. USB (Universal Serial Bus) specification is copyright by Compaq Computer Corporation, Intel Corporation, Microsoft Corporation, and NEC Corporation. Windows is registered trademarks of Microsoft Corporation. Quick Chip is a Visa specification. M/Chip Fast is a Master Card specification.

Augusta KB with Quick Chip and M/Chip Fast is patent-pending.

Revision History

Revision	Date	Description of Changes	By
50	12/20/2015	Initial draft	KT
50a	12/30/2015	Misc. corrections as suggested by Engineering	KT
51	01/12/2016	Misc. updates regarding data formats and serial commands (now called USB communication commands). Remove references to LCD commands and outputs.	KT
52	03/10/2016	Incorporated LM's command tables. Added Appendix on Function IDs. USB descriptors added.	KT
53	03/24/2016	Table format applied to remaining commands. New language added to clarify the difference between ITP and NGA commands. Table added, to clarify the categories of NGA commands.	KT
B	04/08/2016	Add Set Encryption and Get Encryption Control (78 53 01 07 and 78 52 01 07).	KT
C	06/22/2016	Added LCD Foreign Language Mapping Table (for EMV-required LCD messages). Added info for 49 72 01 responses (EMV-required LCD messaging).	KT
D	10/25/2016	Added Terminal Configurations appendix.	KT
K	04/18/2019	Font and format update 13.0: Removed tag DFEF59; it is no longer supported	CB
L	07/08/2019	Added SRED Decommissioning text	CB
M	08/19/2019	Added power consumption specifications	CB
N	11/14/2019	Updated document font and formatting Added Appendix B: LED Behavior	CB
O	01/11/2021	Updated tamper information in Appendix B: LED Behavior Updated 2D dimensions drawing	CB

Table of Contents

1. INTRODUCTION	6
1.1. QUICK CHIP AND M/CHIP FAST SUPPORT.....	7
1.2. SRED SUPPORT.....	7
2. SOFTWARE INTEGRATION.....	8
3. FEATURES.....	9
4. APPLICABLE DOCUMENTS	10
5. SPECIFICATIONS	10
5.1. STRUCTURE.....	10
5.2. DURABILITY/RELIABILITY.....	10
5.3. ENVIRONMENTAL.....	11
5.4. POWER CONSUMPTION.....	11
5.5. POWER MANAGEMENT.....	11
5.6. PHYSICAL DIMENSIONS.....	12
5.7. AGENCY APPROVALS AND COMPLIANCES	13
6. DECOMMISSIONING SRED DEVICES	13
7. BASE FUNCTIONALITY	13
7.1. SMART CARD FUNCTION	13
7.2. MAGNETIC STRIPE FUNCTION.....	13
7.3. INTERFACE FUNCTION	13
7.4. KEY INJECTION FUNCTION.....	13
7.5. REMOTE KEY INJECTION FUNCTION.....	14
7.6. BOOTLOADER FUNCTION.....	14
8. USB COMMUNICATION.....	15
8.1. ITP PROTOCOL FORMAT.....	15
8.2. NGA PROTOCOL FORMAT	16
8.3. USB DESCRIPTORS.....	17
8.3.1. USB-HID.....	17
8.3.2. USB-KB	20
8.4. USB KB COMMUNICATION COMMAND AND RESPONSE FORMAT	24
8.3.3. Data Formats	25
8.3.4. MSR Modes of Operation.....	25
8.3.5. Auto Mode.....	25
8.3.6. Buffer Mode.....	26
9. EMV L2 DATA OUTPUT FORMATS	27
9.1. STANDARD TRANSACTION MODE	27
9.2. NO DATA ENCRYPTION KEY & NO TRANSARMOR CERTIFICATE:.....	27
9.3. TDES/AES MODE & DATA ENCRYPTION KEY EXIST:.....	27
9.4. TRANSARMOR MODE & TRANSARMOR CERTIFICATE EXISTS:.....	28
9.5. QUICK CHIP AND M/CHIP FAST TRANSACTION MODE.....	29
9.6. NO DATA ENCRYPTION KEY & NO TRANSARMOR CERTIFICATE:.....	30
9.7. TDES/AESMODE & DATA ENCRYPTION KEY EXIST:.....	30
9.8. TRANSARMORMODE &TRANSARMOR CERTIFICATE EXIST:	31
10. BASIC OPERATION	32
11. TROUBLESHOOTING	32

12. APPENDIX A: QUICK CHIP AND M/CHIP FAST SUPPORT33
 12.1. HOW TO ENABLE QUICK CHIP AND M/CHIP FAST MODE.....34
 12.2. FASTER EMV (QUICK CHIP) DATA.....35
13. APPENDIX B: LED BEHAVIOR36

1. Introduction

ID TECH's Augusta series reader is a hybrid MagStripe and EMV ICC card reader, built for maximum durability, security, and cost-effectiveness. It is available in both non-SRED (Augusta) and PCI SRED (Augusta S) versions. The standard Augusta supports TDES or AES data encryption (with TransArmor encryption as an option), with DUKPT key management, and remote key injection as an option. An SRED version of the reader, Augusta S, is available for customers who require the tamper protection, fulltime encryption, command authentication, and other features of SRED.

The Augusta product line is specifically designed for a hybrid MagStripe/ICC card environment, and provides user-friendly interface features (such as blue-colored "Point of Interaction" LED indicators) that make it easy and fast for users to determine where and when to swipe or insert cards. A traditional "green/blue/red" LED status indicator provides a clear indication of overall event status. In addition, an audible beeper can indicate alert or error status and remind the user to remove their card at the end of an EMV transaction. Combined, the LEDs and audible beeper features provide user-friendly cues that enable a fast, efficient transaction.

The Augusta product provides a logical migration path for existing ID TECH MiniMag and SecureMag customers to migrate from a magstripe-only POS platform to a platform that provides EMV ICC functionality. Augusta does this by providing a "dual mode" communication structure that allows it to operate in either "Legacy Mode" or "EMV Hybrid Mode."

In Legacy Mode, the Augusta acts as a conventional "MagStripe only" device that is command-compatible with the existing ID TECH SecureMag product line when communicating over USB-KB. This allows the Augusta to be a drop-in, plug-and-play replacement in existing SecureMag environments. Likewise, the Augusta uses the same physical mounting features as the MiniMag II. Thus, existing MiniMag and SecureMag customers can purchase the Augusta as a direct replacement product with confidence that the Augusta's ICC features will "future proof" their investment for migration to an EMV chip-card environment.

In EMV Hybrid Mode, the Augusta transforms into a fully featured EMV L1/L2 ICC and MagStripe card reader using a USB-HID interface. In this mode, the Augusta is no longer command-compatible with the SecureMag product line. This document describes the command set and protocol used in Augusta's EMV Hybrid Mode.

1.1. Quick Chip and M/Chip Fast Support

Augusta-series readers with firmware at V1.01.003 or higher support firmware-integrated Quick Chip and M/Chip Fast, allowing for 2-sec EMV transactions in USB Keyboard mode (compatible with virtual terminals) – a patent-pending ID TECH innovation. (Note: The ID TECH patent applies to the *keyboard-mode* implementation, not Quick Chip itself.) See Appendix A for more information.

1.2. SRED Support

Augusta S incorporates PCI-PTS 4.x SRED (Secure Read and Exchange of Data) support, for the most demanding security environments. Note that Augusta S is dimensionally the same as standard Augusta but has a Part Number that contains '851.' Augusta S supports Quick Chip and M/Chip Fast (as described above and in Appendix A) as well as all normal modes of the standard Augusta, but incorporates additional security features:

- Augusta S incorporates advanced tamper-detection features, including circuitry that will automatically zero out encryption keys (rendering the unit useless to an attacker) if the unit is opened or disassembled.
- Augusta S features fulltime encryption: No sensitive data will ever be output in plaintext format.
- Encryption in SRED mode is TDES.
- Sensitive commands require MAC authentication. In particular, the following commands require authentication in Augusta S:
 - Set White List
 - Set Date & Time
 - Set CA Public Key
 - Set Certification Revocation List
 - New KSN/Key Pair
- Optionally, transaction output may contain a MAC hash of sensitive track data. See further discussion at EMV L2 Data Output as well as the Set Verify Encrypt Data Output command.

2. Software Integration

When it comes to creating software that communicates with the Augusta, the developer has several choices:

- Two-way USB-KB communication via Legacy Mode protocol and command set
- One-way (read only) USB-KB communication in Quick Chip and M/Chip Fast mode
- Direct USB-HID communication via EMV Hybrid Mode protocol and command set
- ID TECH Universal SDK (Supports Windows, iOS, and Android environments)

Windows developers should use the C#-based Universal SDK whenever possible. This powerful development platform reduces integration complexity and cuts development time significantly by providing a library of routines that allow convenience access to commonly used functions. Also, the SDK is supported by sample code and test/debug utilities that make it easier for ID TECH to support the developer.

The Universal SDK and related documentation can be downloaded from the ID TECH website. Please contact ID TECH customer support (support@idtechproducts.com) for further information, or check for the latest downloads on the ID TECH [Knowledge Base](#). Downloads do not require registration.

3. Features

ID TECH's Augusta is a state-of-the-art EMV ICC contact reader with the ability to fall back to conventional magstripe interactions. Its features include the following:

- Encryption-capable 3-track magstripe swipe-reader and EMV ICC "insert" reader
- Supports encrypted or non-encrypted operation
- PCI certified SRED version available
- EMV Level 1 and Level 2 certified
- Built-in support for Quick Chip and M/Chip Fast in keyboard mode (patent pending)
- Compact size, mounting compatible with MiniMag II product
- User-friendly LED indicators for card insertion location/point of interaction
- Tri-color LED to indicate reader status, good/bad card reads, etc.
- Audio feedback to signal good/bad card reads and alert status
- Support for Triple DES or AES encryption methods
- Support for TransArmor encryption
- Support for DUKPT key management
- Supports ID TECH standard TR31 (and optional TR34) based Remote Key Injection
- Rated for 1,000,000 magstripe card swipes and 500,000 ICC card insertions
- On-board battery-backed RTC (Real Time Clock) for transaction timestamping
- RoHS and REACH compliant
- 1-year manufacturer's warranty
- Firmware can be upgraded in the field via the communication interfaces
- SDKs available for C# on Windows and Java on Android
- Tamper detection and tamper-triggered key zeroization (Augusta S only)
- Compatible with virtual terminal environments (keyboard output)

4. Applicable Documents

- ISO 7810 Identification cards -- Physical characteristics
- ISO 7811 Identification Cards -- Tracks 1 through 3
- ISO 7816 Identification cards -- Integrated circuit cards
- ISO 4909 Magnetic stripe content for Track 3
- EMV Contact Specifications for Payment Systems Version 4.3

5. Specifications

5.1. Structure

No.	Item	Specification	Note
1	Physical Dimensions	Maximum 127mm x 52mm x 35mm	L x W x H
2	Structure Material	Plastic	
3	Status LED	Tri-color LED to indicate reader status	Blue, Red, Green
4	ICC LED	Blue LEDs to indicate ICC card insertion	
5	Magnetic Head	3 tracks read head	
6	Head material	Permalloy	
7	Slot width	1.0mm (MSR) or 0.9mm (ICC)	
8	Card format	ISO-7816	
9	ICC Contact force	0.2 to 0.6N	
10	Battery	3.0V lithium	5 yr life
11	Beeper	75db @4KHz	

5.2. Durability/Reliability

No.	Item	Specification
1	Magnetic Head	1,000,000 swipes minimum
2	Rail	1,000,000 swipes minimum
3	Smartcard connector	500,000 inserts minimum
4	Drop Test	Unit is able to withstand 4 ft. drop to concrete on 6 surfaces and 4 corners (6 cycles) and remain functionally intact
5	IK Test	IK08
6	IP Test	IP50 when placed horizontal; IP52 when unit is mounted vertical.
7	Electrostatic discharge	Electronics can survive ESD of 8kV contact, and 12kV air discharge, with no loss of communications
8	MTBF	120,000 POH minimum

5.3. Environmental

Item	Specification		Note
Operating Temperature	0 to 55°C (32 to 131°F)		Non-condensing.
Storage Temperature	-25 to 65°C (-13 to 149°F)		Non-condensing.
Relative humidity	Maximum 95%		Non-condensing
ESD	Contact	±8kV	
	Air discharge	±12KV	

5.4. Power Consumption

Tested Parameter	Current measured
Power on (Normal)	68 mA
Suspend Circuit	1.5 mA
ICC Power On	88 mA (max)
ICC LED ON (Replace LED 5mA)	122 mA
ICC LED ON (Original LED 2mA)	91.6 mA

5.5. Power Management

A USB interface cable provides power from VBUS at 5VDC.

5.6. Physical Dimensions

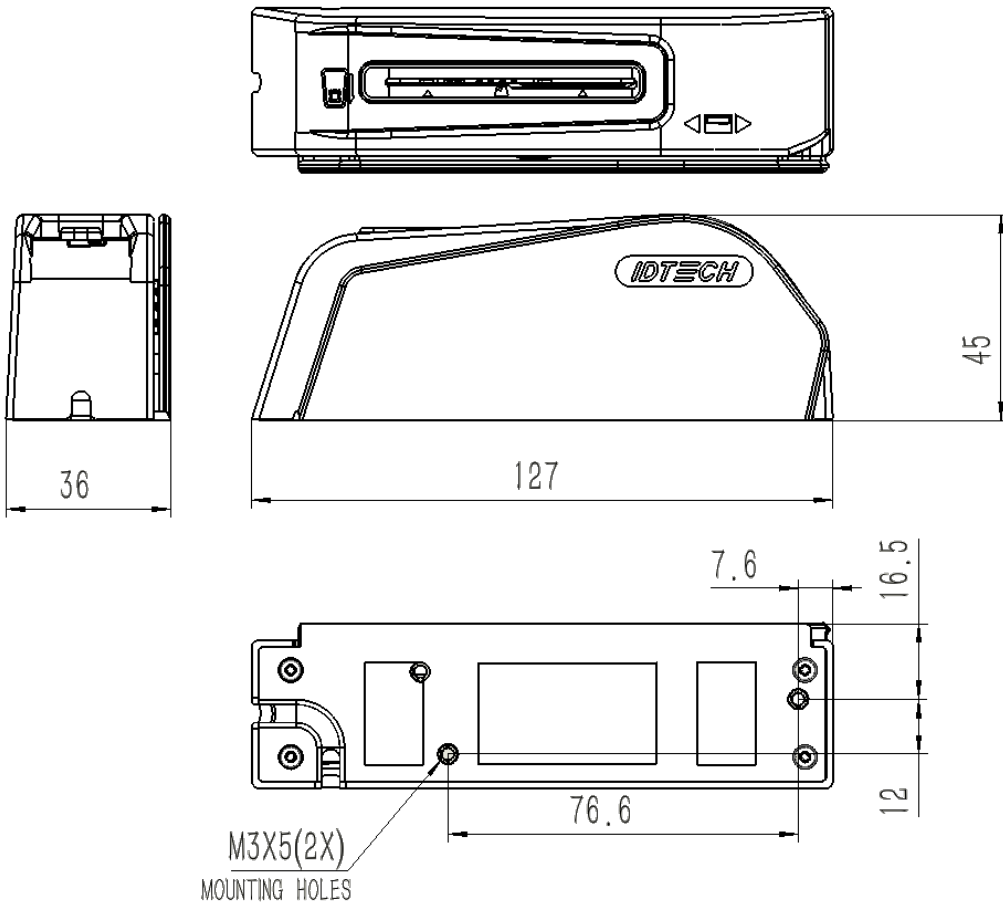

5.7. Agency Approvals and Compliances

Item	Regulation & Class	Note
CE	EN55022/EN55024, Class- B	
FCC	Part 15, Class-B	
RoHS	DIRECTIVE 2011/65/EU Cd < 100ppm Pb,Hg,Cr6+,PBDE,PBB < 1000ppm	
REACH	Compliance with REACH regulation	
EMV	Contact L1&L2	
PCI	SRED 4.1	Augusta S version only
IK rating	IK08	
IP rating	IP52	

6. Decommissioning SRED Devices

All PCI devices require proper decommissioning prior to device disposal in order to ensure the protection of all sensitive financial card data. For instructions on decommissioning your device, see [Decommissioning of SRED Devices](#) on the ID TECH Knowledge Base.

7. Base Functionality

7.1. Smart Card function

- EMV Level 1 approval
- Reads ISO 7816 (1,2,3,4) (T=0, T=1) (Class A, B) microprocessor cards
- Monitor Card Seated Status
- TDES and AES Encryption
- DUKPT key management

7.2. Magnetic Stripe function

- Meets ISO 7811 (Supports AAMVA format and JIS II Card format)
- Support single, dual or triple tracks
- Bi-directional reading
- TDES or AES Encryption
- DUKPT key management
- PCI PTS 4.x Function Supported SRED

7.3. Interface function

The device can communicate with the host via USB-KB or USB-HID.

7.4. Key injection function

Compatible with FutureXHSM for Data Key Injection.

Can communicate with Mobile devices (Related Protocol) via USB-HID port.

(Note: ID TECH is a certified Key Injection Facility. Talk to your ID TECH representative about getting units key-injected.)

7.5. Remote Key Injection function

Compatible with Local POS Computer (LPC) for Data Key Injection.

Can communicate with Local POS Computer (LPC) via USB port.

Contact your ID TECH representative for information about obtaining Remote Key Injection services.

7.6. Bootloader function

The firmware can be upgraded via USB.

8. USB Communication

Two-way communication can occur with Augusta using USB-KB (for SecureMag compatibility mode; that is, magstripe-only operation) or via USB-HID (magstripe plus EMV). When a unit is placed in Quick Chip and M/Chip Fast mode, it operates read-only, in keyboard mode.

In MSR-only Legacy mode (two-way USB-KB, non-Quick-Chip), commands are sent and received using the ID Tech ITP Protocol (a simple command/response scheme that wraps data with start and end codes plus an LRC, or longitudinal redundancy check, value; see below). In combined EMV+MSR mode (that is, USB-HID mode; EMV enabled), commands are sent via ID Tech NGA Protocol (a simple command-and-response scheme; see details further below).

For the complete firmware-command API, see document 80145504-001, *ID TECH Augusta Interface Developer's Guide* (available on the ID TECH [Knowledge Base](#).)

8.1. ITP Protocol Format

- <STX> is defined as 0x02
- <ETX> is defined as 0x03
- <ACK> is defined as 0x06
- <NAK> is defined as 0x15

Configuration Setting Command: <STX><S><FuncSETBLOCK1>...<FuncBLOCKn><ETX><LRC>

Response: <ACK> or <NAK> for wrong command (invalid funcID, length and value)

Configuration Review Command: <STX><R><ReviewID><ETX><LRC>

Response: <ACK> <STX> <FuncID> <Len> <FuncData> <ETX> <LRC 2>

<FuncID>, <Len> and <FuncData> definition are same as described above.

Note: ReviewID (value 0x1F) will return all funcID-s.

Where:

- <Length> = is a two-byte counter (high then low) from <Command ID> to the byte before LRC
- <Command ID> = is a one byte value identifying a specific command ID.
- <FuncID> = is a one byte Function ID, which identifies the particular function or settings affected.
- <Len> = is a one-byte length count for the data block "<FuncData>"
- <FuncData> = is the data block for the function

<Response Data> = is the data block associated with the Response.

<Status> is a two byte value indicating the success or failure of a command. There are a few responses without status. e.g. Version command.

Note that the LRC comes at the end and represents the XOR of all preceding byte values including STX and ETX.

8.2. NGA Protocol Format

<STX><CLenL><CLenH><Command_Body/Response_Body/Notification/Output Body/Input Body>...<LRC> <Checksum><ETX>

- **Function Command**
Command Format:
<TaskID><F><Command>...

Response:

If valid command and no problem during execution

<ACK> [<Response>]...

Otherwise

<NAK><ErrorCode1> [<ErrorCode2>]

- **Setting Command**
Command Format:
<TaskID> <S> <00> or
<TaskID><S><NoFunc><FuncBlock>

Where:

- <TaskID> <S> <00> means Default the Task
- <All (0x7F)> <S> <00> means Default All
- <NoFunc> is number of function blocks to set in a task. Now only support <NoFunc> = 1
- <FuncBlock> has the following format of <FuncID><Len><FuncData>
- <FuncID> is a one byte Property ID.
- <Len> is a one byte length count for a setting <FuncData>.
- <FuncData> is a setting for a property.

Response:

If valid command and no problem during execution

<ACK>

Or (fail)

<NAK><ErrorCode1><ErrorCode2>

For setting command, reader will scan command first and send back error codes if it found any error(s), and do setting if no error has been found.

<Unknown ID in Setting/Review list> (1600) and <Setting value out of range> (1400) will be treated as warning. i.e.: Do setting for other properties but skip setting for those properties which have warning. Warning will be sent to host.

- **Host Review Command**
Command Format:

<TaskID><R><00> or
 <TaskID><R><NoFunc><FuncID>

Where:

<NoFunc> is number of properties to review in a task. Now only support <NoFunc> = 1
 <TaskID><R><00> allows host to review all properties in a task.
 <TaskID><R><01><FuncID> allows host to review setting for a property.

Response:

<ACK><TaskID><NoFunc><FuncBLOCK> or (fail)
 <NAK><ErrorCode1><ErrorCode2>

<TaskID> is needed for each <FuncID> in review command.

Note that in contrast to the ITP format, in NGA protocol the LRC value does *not* come at the end, and does *not* include STX, length bytes, nor ETX in its calculated XOR value.

8.3. USB Descriptors

Following are the USB descriptors used by Augusta. The detailed information should be adjusted and tested as need be during implementation.

8.3.1. USB-HID

Device Descriptor:

Field	Value (Hex)	Description (ACR38)
Length	12	Length = 18
Des type	01	
BCD USB	00 02	USB 2.0
Device Class	00	Not specific
Sub Class	00	Unused
Device Protocol	00	Unused
Max Packet Size	40	Max Packet Size is 64 bytes
VID	0A CD	
PID	38 20 (39 20 for SRED)	
BCD Device Release	00 01	
i-Manufacture	01	
i-Product	02	
i-Serial-Number	03	
# Configuration	01	

Configuration Descriptor:

Field	Value (Hex)	Description
Length	09	
Des type	02	
Total Length	29 00	
No. Interface	01	
Configuration Value	01	
iConfiguration	00	
Attributes	A0	Bus power; With remote wakeup
Power	32	100 mA

Interface Descriptor: (USB-HID)

Field	Value (Hex)	Description
Length	09	
Des type	04	
Interface No.	00	
Alternator Setting	00	
# EP	02	
Interface Class	03	HID
Sub Class	00	
Interface Protocol	00	
iInterface	00	

HID Descriptor:

Field	Value (Hex)	Description
Length	09	
bDescriptorType	21	HID
bcdHID(L/H)	11 01	Rev 1.11
bCountryCode	00	
bNumDescriptors	01	
bDescriptorType	22	Report
wDescriptorLength(L/H)	1C 00	L H

End Point Descriptor: (EP2)

Field	Value	Description
Length	07	
Des Type	05	End Point
EP Addr	02	EP2 Out, Command Down
Attributes	03	Interrupt
wMaxPacketSize	40 00	64 Bytes
bInterval	04	4 milliseconds

End Point Descriptor: (EP1)

Field	Value	Description
Length	07	
Des Type	05	End Point
EP Addr	81	EP1 In, Response Up
Attributes	03	Interrupt
Size	40 00	64 Bytes
Interval	04	4 milliseconds

8.3.2. USB-KB

USB-KB communication may be used when the Augusta is in SecureMag-compatibility mode (magstripe only). For EMV/ICC-enabled operation, use USB-HID instead.

Device Descriptor:

Field	Value (Hex)	Description (ACR38)
Length	12	Length = 18
Des type	01	
bcdUSB	00 02	USB 2.0
Device Class	00	Not specific
Sub Class	00	Unused
Device Protocol	00	Unused
Max Packet Size	08	Max Packet Size is 8 bytes
VID	0A CD	
PID	38 10 (39 10 for SRED)	
BCD Device Release	00 01	
i-Manufacture	01	
i-Product	02	
i-Serial-Number	03	
# Configuration	01	

Configuration Descriptor:

Field	Value (Hex)	Description
Length	09	
Des type	02	
Total Length	22 00	
No. Interface	01	
Configuration Value	01	
iConfiguration	00	
Attributes	80	Bus power; Without remote wakeup
Power	32	100 mA

Interface Descriptor: (USB-HID)

Field	Value (Hex)	Description
Length	09	
Des type	04	
Interface No.	00	
Alternator Setting	00	
# EP	01	
Interface Class	03	HID
Sub Class	01	01:boot

Interface Protocol	02	02:keyboard
ilnterface	00	

HID Descriptor:

Field	Value (Hex)	Description
Length	09	
bDescriptorType	21	HID
bcdHID(L/H)	11 01	Rev 1.11
bCountryCode	00	
bNumDescriptors	01	
bDescriptorType	22	Report
wDescriptorLength(L/H)	52 00	L H

End Point Descriptor: (EP1)

Field	Value	Description
Length	07	
Des Type	05	End Point
EP Addr	81	EP1 In
Attributes	03	Interrupt
Size	08 00	8 Bytes
Interval	01	1 milliseconds

HID report descriptor for IDTech Key Board Protocol

Field	Value (Hex)	Description
Usage Page	05 01	Generic Desktop
Usage	09 06	Keyboard
Collection	A1 01	Application
Usage Page	05 07	Key codes
Usage Minimum	19 E0	224
Usage Maximum	29 E7	231
Logical Minimum	15 00	0
Logical Maximum	25 01	1
Report Size	75 01	1
Report Count	95 08	8
Input	81 02	Data, Variable, Absolute
Report Count	95 01	1
Report Size	75 08	
Input	85 01	Constant
Report Count	95 05	5
Report Size	75 01	
Usage Page	05 08	LED
Usage Minimum	19 01	1
Usage Maximum	29 05	5
Output	91 02	Data Var Absolute

Report Count	95 01	1
Report Size	75 03	
Output	91 01	Constant
Report Count	95 06	6
Report Size	75 08	
Logical Minimum	15 00	0
Logical Maximum	25 66	102
Usage Page	05 07	Keycodes
Usage Minimum	19 00	
Usage Maximum	29 66	102
Input	81 00	Data,Array
Usage Page	06 2D FF	ID TECH
Report Count	95 01	1
Logical maximum	26 FF 00	255
Logical Minimum	15 01	
Report Size	75 08	
Usage	09 20	Setup data byte
Report Count	95 08	
Feature	B2 02 01	Data Var, Abs
End Collection	C0	

8.4. USB KB Communication Command and Response Format

The Augusta supports USB-KB communication (only) while in "Legacy Mode."

Legacy Mode is compatible with ID TECH's "SecureMag" magstripe-only card reader.

Please see ID TECH manual P/N 80096504-001, the SecureMag Encrypted MagStripe Reader User Manual, for additional information regarding the SecureMag (Legacy Mode) protocol and command set.

Note that USB-KB commands use ID Tech's ITP protocol, in which commands are wrapped with STX (0x02) and ETX (0x03), followed by an LRC value that represents the XOR of all preceding byte values. (No checksum is used.) For example:

Command: 52 22 (Get Firmware Version)

This command would be sent as (hex) 02 52 22 03 71, where 0x71 is the LRC value.

USB HID Communication Command and Response Format

In EMV Hybrid Mode, Augusta uses ID TECH proprietary NGA protocol format commands and responses in USB communications. The NGA protocol exchanges data using the following format:

```
<0x02> <Len_Low><Len_High> <Command Body/Response
Body/Notification Body> <LRC> <CheckSUM> <0x03>
```

Where:

- <0x02> is STX (Start of Text)
- <Len_Low><Len_High> is the length of the <Command Body/Response Body/Notification Body> in hexadecimal byte values.
- <LRC> is LRC (exclusive OR) of <Command Body/Response Body/Notification Body> byte values. (XOR all bytes together. The result is the LRC.)
- <CheckSUM> is SUM of <Command Body/Response Body/Notification Body> values, disregarding overflow. (Add all bytes; the result, mod-256, is the checksum.)
- <0x03> is ETX (End of Text)
- Response Body is [<Response Status> + <Response Data>]
 - <Response Status>: 1 byte.
 - <Response Data>: n bytes.
 - If <Response Status> is ACK, Several bytes needed.
 - If <Response Status> is NAK, Response data is Error code (2 bytes), or Error code (2 bytes) + Tag (1 or 2 bytes; this is for ICC L2 response).
- Command Body is [<Command> + <Command Parameters>]
- Notification Body is [xxxxxxxxxxxxxxxxxxxxxxx]

Note that NGA commands tend to begin with a high nibble value 7:

Command Prefix	Category
72	ICC (smart card commands)
73	MSR (magstripe commands)
75	PCI Miscellaneous
78	Configuration commands
7F	Reserved

In a multi-byte NGA command, the first byte indicates the category (as shown above); the second byte is typically one of 'F', 'R', or 'S' (Function, Read, Set; hex 0x46, 0x52, or 0x53 respectively); and the third byte is the specific function ID.

8.3.3. Data Formats

Note that when a chip-card (ICC) transaction is performed, EMV data will be returned using a tag-based (TLV) representation as described in detail in ID TECH P/N 80000502-001 *ID Tech Encrypted Data Output*.

When a conventional magstripe (MSR) transaction is performed, MSR data will be returned following the ID TECH Enhanced Encrypted MSR Data Format described in ID TECH P/N 80000502-001 *ID Tech Encrypted Data Output*.

8.3.4. MSR Modes of Operation

MSR operation occurs in two modes: Auto or Buffer.

8.3.5. Auto Mode

Auto mode means MSR data will be auto sent out once magnetic card was swiped.

It is supported only in USB-KB interface; it is the default behavior. Auto Mode can be disabled.

After MSR data were auto-sent out, the Buffer Data will be erased directly.

8.3.6. Buffer Mode

Buffer mode means MSR data will be sent out in response to the Read Buffer Data command.

It is supported in USB-HID interface or USB-KB interface. Buffer Mode can be disabled.

Implementation:

	USB-KB with ITP Protocol	USB-HID with NGA Protocol
Step 0	If device is Auto Mode or Disable Buffer Mode, Set to Enable Buffer Mode.	If device is Disable Buffer Mode, Set to Enable Buffer Mode.
Step 1	Send "Arm to Read" Command. If receive ACK, enter next step.	Send "Arm to Read" Command. If receive ACK, enter next step.
Step 2	<p>While in this state, User can swipe Card. Timeout is 30 seconds.</p> <p>Send "Read Buffer Data" to read MSR data. The response should be:</p> <ul style="list-style-type: none"> ▪ NAK for No Swipe Card and No Timeout, and Buffer is erased. or ▪ NAK for No Swipe Card and Timeout. or ▪ ACK + "Successful MSR Data" for swipe OK, and Buffer is erased. or ▪ NAK for swipe failed, and Buffer is erased. <p>If send "Read Buffer Data" before send "Arm to Read", the response should be 0x18.</p> <p>After Swipe Card, the MSR data should be exist at most 15 Minutes. If timeout, Buffer is erased.</p>	<p>While in this state, User can swipe Card. Timeout is 30 seconds.</p> <p>Send "Read Buffer Data" to read MSR data. The response should be:</p> <ul style="list-style-type: none"> ▪ NAK + "No Swipe Card Error" for No Swipe Card and No Timeout, and Buffer is erased. or ▪ NAK + "Timeout Error" for No Swipe Card and Timeout. or ▪ "Successful MSR Data" for swipe OK, and Buffer is erased. or ▪ NAK + "Failed Get MSR Data" for swipe failed, and Buffer is erased. <p>If send "Read Buffer Data" before send "Arm to Read", the response should be NAK + "Operate Error"</p> <p>After Swipe Card, the MSR data should be exist at most 15 Minutes. If timeout, Buffer is erased.</p>

9. EMV L2 Data Output Formats

9.1. Standard Transaction Mode

The following sections describe data outputs that apply in USB-HID mode (as opposed to Keyboard mode involving Quick Chip; see [Quick Chip and M/Chip Fast Transaction Mode](#) further below for more details). For additional detail on data output formats for MSR and EMV, see ID TECH document 80000502-001, *ID TECH Encrypted Data Output Formats.pdf*, available from <https://atlassian.idtechproducts.com/confluence/display/KB/Downloads+-+Home>.

9.2. No Data encryption Key & No TransArmor Certificate:

ErrorResponse Body: 15 04 00

The Response Data – 02 <Len_L><Len_H>15 04 00<LRC><SUM> 03

9.3. TDES/AES mode & Data encryption Key exist:

Without MAC Data Output:

EMV L2 Transaction Result – 06 <2 bytes Response Code><Attribution><DF EF 12 0A (10 bytes KSN)><5A A1 08 (8 bytes Tag5A Mask Data)><5A C1 10 (16 bytes Tag5A Encryption Data)><57 A1 13 (19 bytes Tag57 Mask Data)><57 C1 18/20 (24 bytes/32bytes Tag57 Encryption Data)><9F 1F C1 N (N bytes Tag9F1F Encryption Data)><9F 20 n (n bytes Raw Value)><TLV1><TLV2> ... <TLVn><DF EF 4C 06 00 26 00 10 00 00><DF EF 4D 38/40 (56/64 bytes Encrypted Trk1_Data Trk2_Data Trk3_Data PAN_Data)>

The Response Data – 02 <Len_L><Len_H> 06 <2 bytes Response Code><Attribution><DF EF 12 0A (10 bytes KSN)><5A A1 08 (8 bytes Tag5A Mask Data)><5A C1 10 (16 bytes Tag5A Encryption Data)><57 A1 13 (19 bytes Tag57 Mask Data)><57 C1 18/20 (24 bytes/32bytes Tag57 Encryption Data)><9F 1F C1 N (N bytes Tag9F1F Encryption Data)><9F 20 n (n bytes Raw Value)><TLV1><TLV2> ... <TLVn><DF EF 4C 06 00 26 00 10 00 00><DF EF 4D 38/40 (56/64 bytes Encrypted Trk1_Data Trk2_Data Trk3_Data PAN_Data)><LRC><SUM> 03

With MAC Data Output:

EMV L2 Transaction Result – 06 <2 bytes Response Code><Attribution><DF EF 12 0A (10 bytes KSN)><5A A1 08 (8 bytes Tag5A Mask Data)><5A C1 10 (16 bytes Tag5A Encryption Data)><57 A1 13 (19 bytes Tag57 Mask Data)><57 C1 18/20 (24 bytes/32bytes Tag57 Encryption Data)><9F 1F C1 N (N bytes Tag9F1F Encryption Data)><9F 20 n (n bytes Raw Value)><TLV1><TLV2> ... <TLVn><DF EF 4C 06 00 26 00 10 00 00><DF EF 4D 38/40 (56/64 bytes Encrypted Trk1_Data Trk2_Data Trk3_Data PAN_Data)><DF EF 41 10 (16 bytes MAC Value)><DF EF 42 0A (10 bytes MAC Key KSN)>

The Response Data – 02 <Len_L><Len_H> 06 <2 bytes Response Code><Attribution><DF EF 12 0A (10 bytes KSN)><5A A1 08 (8 bytes Tag5A Mask Data)><5A C1 10 (16 bytes Tag5A Encryption Data)><57 A1 13 (19

bytes Tag57 Mask Data)><57 C1 18/20 (24 bytes/32bytes Tag57 Encryption Data)><9F 1F C1 N (N bytes Tag9F1F Encryption Data)><9F 20 n (n bytes Raw Value)><TLV1><TLV2> ... <TLVn><DF EF 4C 06 00 26 00 10 00 00><DF EF 4D 38/40 (56/64 bytes Encrypted Trk1_Data Trk2_Data Trk3_Data PAN_Data)><DF EF 41 10 (16 bytes MAC Value)><DF EF 42 0A (10 bytes MAC Key KSN)><LRC><SUM> 03

9.4. TransArmor Mode & TransArmor Certificate Exists:

Without MAC Data Output:

Step1:

EMV L2 Transaction Result - 06 <2 bytes Response Code><Attribution><DF EF 12 0A (10 bytes KSN)><DF EE 26 02 (2 bytes data)><5A A1 08 (8 bytes Tag5A Mask Data)><5A C201 58 (344 bytes Tag5A TransArmor Data)><57 A1 13 (19 bytes Tag57 Mask Data)><57 C201 58 (344 bytes Tag57 TransArmor Data)><TLV1><TLV2> ... <TLVn><DF EF 48 0A DF EF 4C DF EF 4D 9F 1F 9F 20>

The Response Data - 02 <Len_L><Len_H> 06 <2 bytes Response Code><Attribution><DF EF 12 0A (10 bytes KSN)><DF EE 26 02 (2 bytes data)><5A A1 08 (8 bytes Tag5A Mask Data)><5A C201 58 (344 bytes Tag5A TransArmor Data)><57 A1 13 (19 bytes Tag57 Mask Data)><57 C201 58 (344 bytes Tag57 TransArmor Data)><TLV1><TLV2> ... <TLVn><DF EF 48 0A DF EF 4C DF EF 4D 9F 1F 9F 20><LRC><SUM> 03

Step2:

Terminal can send "Retrieve Transaction Result" command with 4 tags (DFEF4C, DFEF4D, 9F1F and 9F20) to get them.

The response Data - 06 <DF EF 4C 06 00 26 00 10 00 00><DF EF 4D 82 02 B0 (344 bytes Tag57 TransArmor Data) (344 bytes Tag5A TransArmor Data)><9F 1F C2 01 58 (344 bytes Tag9F1F TransArmor Data) ><DF EF 48 02 9F 20>

The Response Data - 02 <Len_L><Len_H> 06 <DF EF 4C 06 00 26 00 10 00 00><DF EF 4D 82 02 B0 (344 bytes Tag57 TransArmor Data) (344 bytes Tag5A TransArmor Data)><9F 1F C2 01 58 (344 bytes Tag9F1F TransArmor Data) ><DF EF 48 02 9F 20><LRC><SUM> 03

Step3:

Terminal can send "Retrieve Transaction Result" command with 4 tags (9F20) to get them

The response Data - 06 <9F 20 C2 01 58 (344 bytes Tag9F20 TransArmor Data) >

The Response Data - 02 <Len_L><Len_H> 06 <9F 20 C2 01 58 (344 bytes Tag9F20 TransArmor Data) ><LRC><SUM> 03

With MAC Data Output:**Step1:**

EMV L2 Transaction Result – 06 <2 bytes Response Code><Attribution><DF EF 12 0A (10 bytes KSN)><DF EE 26 02 (2 bytes data)><5A A1 08 (8 bytes Tag5A Mask Data)><5A C201 58 (344 bytes Tag5A TransArmor Data)><57 A1 13 (19 bytes Tag57 Mask Data)><57 C201 58 (344 bytes Tag57 TransArmor Data)><TLV1><TLV2> ... <TLVn><DF EF 48 0A DF EF 4C DF EF 4D 9F 1F 9F 20><DF EF 41 10 (16 bytes MAC Value)><DF EF 42 0A (10 bytes MAC Key KSN)>

The Response Data – 02 <Len_L><Len_H> 06 <2 bytes Response Code><Attribution><DF EF 12 0A (10 bytes KSN)><DF EE 26 02 (2 bytes data)><5A A1 08 (8 bytes Tag5A Mask Data)><5A C201 58 (344 bytes Tag5A TransArmor Data)><57 A1 13 (19 bytes Tag57 Mask Data)><57 C201 58 (344 bytes Tag57 TransArmor Data)><TLV1><TLV2> ... <TLVn><DF EF 48 0A DF EF 4C DF EF 4D 9F 1F 9F 20><DF EF 41 10 (16 bytes MAC Value)><DF EF 42 0A (10 bytes MAC Key KSN)><LRC><SUM> 03

Step2:

Terminal can send “Retrieve Transaction Result” command with 4 tags (DFEF4C, DFEF4D, 9F1F and 9F20) to get them

The response Data - 06 <DF EF 4C 06 00 26 00 10 00 00><DF EF 4D 82 02 B0 (344 bytes Tag57 TransArmor Data) (344 bytes Tag5A TransArmor Data)><9F 1F C2 01 58 (344 bytes Tag9F1F TransArmor Data) ><DF EF 48 02 9F 20><DF EF 41 10 (16 bytes MAC Value)><DF EF 42 0A (10 bytes MAC Key KSN)>

The Response Data – 02 <Len_L><Len_H> 06 <DF EF 4C 06 00 26 00 10 00 00><DF EF 4D 82 02 B0 (344 bytes Tag57 TransArmor Data) (344 bytes Tag5A TransArmor Data)><9F 1F C201 58 (344 bytes Tag9F1F TransArmor Data) ><DF EF 48 02 9F 20><DF EF 41 10 (16 bytes MAC Value)><DF EF 42 0A (10 bytes MAC Key KSN)><LRC><SUM> 03

Step3:

Terminal can send “Retrieve Transaction Result” command with 4 tags (9F20) to get them

The response Data - 06 <9F 20 C2 01 58 (344 bytes Tag9F20 TransArmor Data) ><DF EF 41 10 (16 bytes MAC Value)><DF EF 42 0A (10 bytes MAC Key KSN)>

The Response Data – 02 <Len_L><Len_H> 06 <9F 20 C2 01 58 (344 bytes Tag9F20 TransArmor Data) ><DF EF 41 10 (16 bytes MAC Value)><DF EF 42 0A (10 bytes MAC Key KSN)><LRC><SUM> 03

9.5. Quick Chip and M/Chip Fast Transaction Mode

This mode of operation is used in conjunction with USB "Keyboard" mode (KB), a mode in which the card reader acts as a keyboard device, outputting data spontaneously upon card presentation.

9.6. No Data encryption Key & No TransArmor Certificate:

Error Response Body: 15 04 00

The Response Data – 02 <Len_L><Len_H>15 04 00<LRC><SUM> 03

9.7. TDES/AESmode & Data encryption Key exist:**Transaction OK:**

EMV L2 Transaction Result – 06 <2 bytes Response Code><Attribution><DF EF 12 0A (10 bytes KSN)><DF EF 5B 08 (8 bytes Tag5A Mask Data)><5A 10 (16 bytes Tag5A Encryption Data)><DF EF 5D 13 (19 bytes Tag57 Mask Data)><57 18/20 (24 bytes/32bytes Tag57 Encryption Data)><9F 1F N (N bytes Tag9F1F Encryption Data)><9F 20 N (N bytes Raw Value)><TLV1><TLV2> ... <TLVn><DF EF 4C 06 00 26 00 10 00 00><DF EF 4D 38/40 (56/64 bytes Encrypted Trk1_Data Trk2_Data Trk3_Data PAN_Data)>

Without MAC Data Output:

KB final output (Ascii Code) – <DF EE 25 02 (2 bytes Response Code)><DF EE 26 02 (2 bytes Attribution)><DF EF 12 0A (10 bytes KSN)><DF EF 5B 08 (8 bytes Tag5A Mask Data)><5A 10 (16 bytes Tag5A Encryption Data)><DF EF 5D 13 (19 bytes Tag57 Mask Data)><57 18/20 (24 bytes/32bytes Tag57 Encryption Data)><9F 1F N (N bytes Tag9F1F Encryption Data)><9F 20 N (N bytes Raw Value)><TLV1><TLV2> ... <TLVn><DF EF 4C 06 00 26 00 10 00 00><DF EF 4D 38/40 (56/64 bytes Encrypted Trk1_Data Trk2_Data Trk3_Data PAN_Data)>

With MAC Data Output:

KB final output (Ascii Code) – <DF EE 25 02 (2 bytes Response Code)><DF EE 26 02 (2 bytes Attribution)><DF EF 12 0A (10 bytes KSN)><DF EF 5B 08 (8 bytes Tag5A Mask Data)><5A 10 (16 bytes Tag5A Encryption Data)><DF EF 5D 13 (19 bytes Tag57 Mask Data)><57 18/20 (24 bytes/32bytes Tag57 Encryption Data)><9F 1F N (N bytes Tag9F1F Encryption Data)><9F 20 N (N bytes Raw Value)><TLV1><TLV2> ... <TLVn><DF EF 4C 06 00 26 00 10 00 00><DF EF 4D 38/40 (56/64 bytes Encrypted Trk1_Data Trk2_Data Trk3_Data PAN_Data)><DF EF 41 10 (16 bytes MAC Value)><DF EF 42 0A (10 bytes MAC Key KSN)>

Note: msgX is <DF EE 25 02 (2 bytes Response Code)><DF EF 4C 06 00 26 00 10 00 00><DF EF 4D 38/40 (56/64 bytes Encrypted Trk1_Data Trk2_Data Trk3_Data PAN_Data)><DF EF 41 10>

Transaction Error:

EMV L2 Transaction Result – 15 + <2 bytes Error Code>

KB final output (Ascii Code) – <DF EF 61 02 (2 bytes Error Code)>

9.8. TransArmormode & TransArmor Certificate exist:

Step1:

Transaction OK:

EMV L2 Transaction Result – 06 <2 bytes Response Code><Attribution><DF EF 12 0B (11 bytes KID)><DF EE 26 02 (2 bytes data)><DF EF 5B 08 (8 bytes Tag5A Mask Data)><5A 8201 58 (344 bytes Tag5A TransArmor Data)><DF EF 5D 13 (19 bytes Tag57 Mask Data)><57 8201 58 (344 bytes Tag57 TransArmor Data)><TLV1><TLV2> ... <TLVn><DF EF 48 0A DF EF 4C DF EF 4D 9F 1F 9F 20>

Without MAC Data Output:

KB final output (Ascii Code) – <DF EE 25 02 (2 bytes Response Code)><DF EE 26 02 (2 bytes Attribution)><DF EF 12 0B (11 bytes KID)><DF EE 26 02 (2 bytes data)><DF EF 5B 08 (8 bytes Tag5A Mask Data)><5A 8201 58 (344 bytes Tag5A TransArmor Data)><DF EF 5D 13 (19 bytes Tag57 Mask Data)><57 8201 58 (344 bytes Tag57 TransArmor Data)><TLV1><TLV2> ... <TLVn><DF EF 48 0A DF EF 4C DF EF 4D 9F 1F 9F 20>

With MAC Data Output:

KB final output (Ascii Code) – <DF EE 25 02 (2 bytes Response Code)><DF EE 26 02 (2 bytes Attribution)><DF EF 12 0B (11 bytes KID)><DF EE 26 02 (2 bytes data)><DF EF 5B 08 (8 bytes Tag5A Mask Data)><5A 8201 58 (344 bytes Tag5A TransArmor Data)><DF EF 5D 13 (19 bytes Tag57 Mask Data)><57 8201 58 (344 bytes Tag57 TransArmor Data)><TLV1><TLV2> ... <TLVn><DF EF 48 0A DF EF 4C DF EF 4D 9F 1F 9F 20><DF EF 41 10 (16 bytes MAC Value)><DF EF 42 0A (10 bytes MAC Key KSN)>
Note: msgX is <DF EE 25 02 (2 bytes Response Code)> <DF EF 41 10>

Transaction Error:

EMV L2 Transaction Result – 15 + <2 bytes Error Code>

KB final output (Ascii Code) - <DF EF 61 02 (2 bytes Error Code)>

Step2:

Without MAC Data Output:

KB final output (Ascii Code) – <DF EF 4C 06 00 26 00 10 00 00><DF EF 4D 82 02 B0 (344 bytes Tag57 TransArmor Data) (344 bytes Tag5A TransArmor Data)><9F 1F 82 01 58 (344 bytes Tag9F1F TransArmor Data) ><DF EF 48 02 9F 20>

With MAC Data Output:

KB final output (Ascii Code) – <DF EF 4C 06 00 26 00 10 00 00><DF EF 4D 82 02 B0 (344 bytes Tag57 TransArmor Data) (344 bytes Tag5A TransArmor Data)><9F 1F 82 01 58 (344 bytes Tag9F1F TransArmor Data) ><DF EF 48 02 9F 20><DF EF 41 10 (16 bytes MAC Value)><DF EF 42 0A (10 bytes MAC Key KSN)>
Note: msgX is <DF EF 4C 06 00 26 00 10 00 00> <DF EF 41 10>

Step3:**Without MAC Data Output:**

KB final output (Ascii Code) – <9F 20 82 01 58 (344 bytes Tag9F20 TransArmor Data) >

With MAC Data Output:

KB final output (Ascii Code) – <9F 20 82 01 58 (344 bytes Tag9F20 TransArmor Data) ><DF EF 41 10 (16 bytes MAC Value)><DF EF 42 0A (10 bytes MAC Key KSN) >

Note: msgX is <9F 20 82 01 58 (344 bytes Tag9F20 TransArmor Data) ><DF EF 41 10>

10. Basic Operation

The Augusta derives its power from the 5VDC associated with the USB connection. (No extra power cords are needed.) Simply plug the Augusta into any PC, laptop, or other host that supports standard USB-A connectivity.

Note: No special drivers are needed in order to use Augusta. If your Windows machine pauses to download a driver automatically, the first time you plug in your Augusta, simply accept all defaults, and continue.

To perform a magstripe read, slide a card (stripe facing the body of the Augusta) through the side slot of the Augusta, in either direction.

To perform a chip-card transaction, dip a chip card into the ICC slot and remove it when the unit beeps or your POS software indicates that you should remove your card.

11. Troubleshooting

The Augusta is extremely simple and reliable, and should require no special troubleshooting. If the power-on light fails to illuminate when the unit is plugged in, try plugging the Augusta into a known-good USB receptacle (possibly on a different machine). Likewise, if communication with Augusta is ever lost, simply unplug the unit and plug it back in; communication should be restored.

Augusta has no user-serviceable parts and should not be disassembled in any way. Augusta S, in particular, incorporates anti-tamper features that will activate if any attempt is made to disassemble the unit. (Any cryptographic keys in the unit will be erased, and the unit will need to be sent back to the manufacturer to be made serviceable again.)

If you should need to open a customer support case, visit the ID TECH [Support Site](#) or send an e-mail to support@idtechproducts.com (which will automatically open a Tech Support case).

12. Appendix A: Quick Chip and M/Chip Fast Support

ID TECH Augusta-series readers are designed to support the Quick Chip and M/Chip Fast EMV modality when operating in USB-KB mode. This is sometimes referred to as Faster EMV.

Quick Chip and M/Chip Fast is a particular way of doing contact-EMV transactions, designed to shorten the amount of time the cardholder spends waiting to remove his or her card from the reader. For most chip cards, the overall "card inserted" time is on the order of 2.0 seconds. (For cards that lack Payment System Environment capability on the chip, the overall time can be as long as 7.0 seconds, because communication with the gateway or acquirer may be required before the card can be removed from the reader. In Quick Chip, this communication can occur after the card is already removed from the reader.)

Quick Chip and M/Chip Fast is an *online-only* style of interaction, hence it is especially appropriate for markets that are traditionally online-only, such as the U.S. retail market. It relies on terminal configuration changes (not kernel changes), and a hard-coded chain of events surrounding Gen AC requests, to achieve its functional goals. For detailed information about how Quick Chip and M/Chip Fast works, be sure to consult the [U.S. Payments Forum white paper](#).

ID TECH's Augusta-series readers offer Faster EMV, or Quick Chip and M/Chip Fast capability, in conjunction with USB-Keyboard (USB-KB) mode, which is a patent-pending combination that allows Augusta to provide EMV-readiness in a virtual terminal environment. Combining EMV with Keyboard Mode means it becomes exceptionally easy for virtual terminals to support contact EMV transactions in a browser environment.

When a customer presents a card for a Quick Chip and M/Chip Fast transaction, Augusta reads the card (and carries out all the usual steps of an EMV transaction, except for Issuer Authentication and the processing of Issuer Scripts; these steps are not done in Quick Chip and M/Chip Fast), and then it outputs TLV data as *keystrokes* (which is to say, ASCII-renderable hex values) straight to the host computer. The "keystrokes" will show up in whatever text window (or text field, in a web form) currently has focus. (The payment application can intercept these keystrokes as needed, to parse/filter them, insert appropriate values in appropriate form fields, and/or go online for authorization.)

The following section describes the configuration steps needed to put an Augusta reader into Quick Chip and M/Chip Fast Mode. Please note that once the reader is in this mode, all EMV transactions will occur in USB-KB mode using Quick Chip and M/Chip Fast. (MSR transactions will occur in USB-KB mode as well.) It is possible to switch the reader back to USB-HID mode at any time.

The procedures and screenshots below assume that the user is able to utilize ID TECH's Windows-based Universal Demo software (available for free download on the ID TECH [Knowledge Base](#)).

12.1. How To Enable Quick Chip and M/Chip Fast Mode

To enable Quick Chip and M/Chip Fast, first ensure that the reader's firmware is at V1.01.003 or higher. Then perform the following steps.

1. Enable the 5C configuration of Terminal Capabilities by issuing the 72 53 01 28 01 35 command. (For more about terminal configurations, see Appendix H.)
2. Use the Save Terminal Configuration command in the Universal Demo to set the values of minor-config terminal TLVs as desired, making sure 5C is enabled. (See arrows in the screen shot below.)

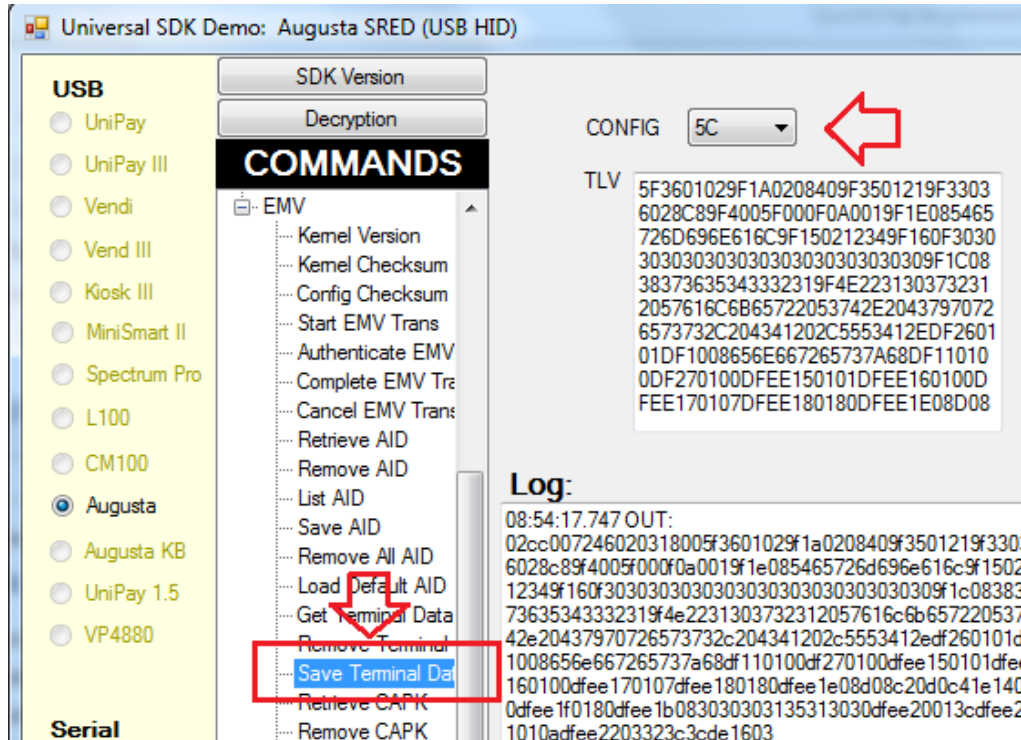

3. Set the CA Public Key if it has never been set, and load any AIDs or do any other initializations you wish to do, before proceeding.
4. Set the device to Quick Chip and M/Chip Fast Mode by issuing the following command: 72 53 01 29 01 31.
5. Finally, change the device's USB mode to USB-KB by issuing the following command: 78 53 01 10 02 02 00.

12.2. Faster EMV (Quick Chip) Data

The output from a Quick Chip and M/Chip Fast transaction consists predominantly of standard EMV tag data, since Quick Chip and M/Chip Fast is, in fact, just EMV. However, you might also encounter certain ID TECH proprietary tags (as follows):

Tag	Meaning
DFEF5A	Terminal Data Setting - Tags to Return
DFEF5B	Mask for Tag5A
DFEF5C	Mask for Tag56
DFEF5D	Mask for Tag57
DFEF5E	Mask for Tag9F6B
DFEF5F	Mask for TagFFEE13 (track 1)
DFEF60	Mask for TagFFEE14 (track 2)
DFEF61	Error Code
DFEF62	Allow MSR Swipe data from ICC Card

Send tags DFEF5A and/or DFEF62 as Terminal Configuration values to control (respectively) the Default Amount of the transaction (normally zero, for Quick Chip), the "tags to return" as part of each transaction, and whether or not to enforce a policy of preferring EMV over MSR if a card has a chip. For tag DFEF62, if the value = 0x01, then any MSR swipe with an ICC card requires the card to be inserted instead of returning MSR swipe data. (In other words: MSR swipe data from an ICC card can *only* be captured in a fallback situation.) If the value = 0x00, any card swiped (MSR or ICC) is allowed to return MSR swipe data.

Other tags returned in a Quick Chip transaction will conform to EMVCo standard usage. Some tags may be encrypted: for details, see ID TECH document P/N 80000502-001, *Encrypted Data Output*.

An example of USB-KB data output from a Quick Chip and M/Chip Fast transaction (using Visa ADVT Test Card No. 43) is:

```

DF EE 25 02 00 02 DF EE 26 02 20 00 DF EE 12 0A 62 99 49 00 75 00 02 A0 02
90 DF EF 5D 11 47 61 CC CC CC CC 04 32 D1 01 22 01 CC CC CC CC CC 57 18 D0 18
2C 6B 2D F9 C4 D2 CD 60 B7 74 C7 65 AF 14 0E 7B 53 F7 78 39 62 9A DF EF
5B 08 47 61 CC CC CC CC 04 32 5A 08 D0 18 2C 6B 2D F9 C4 D2 5F 20 1A 56 49 53
41 20 41 43 51 55 49 52 45 52 20 54 45 53 54 20 43 41 52 44 20 34 33 5F
24 03 10 12 31 5F 25 03 95 07 01 5F 28 02 08 40 5F 2A 02 08 40 5F 2D 00 5F
34 00 5F 57 01 00 50 0B 56 49 53 41 20 43 52 45 44 49 54 4F 00 82 02 5C
00 84 07 A0 00 00 00 03 10 10 8C 15 9F 02 06 9F 03 06 9F 1A 02 95 05 5F 2A 02
9A 03 9C 01 9F 37 04 8D 17 8A 02 9F 02 06 9F 03 06 9F 1A 02 95 05 5F 2A 02 9A
03 9C 01 9F 37 04 8E 0E 00 00 00 00 00 00 00 00 00 00 1E 03 02 03 1F 00 9C 01 00 9F
02 06 00 00 00 00 00 00 9F 03 06 00 00 00 00 00 00 9F 10 07 06 01 0A 03 21 99
00 9F 13 00 9F 20 00 9F 26 08 34 BB F5 DC 19 F3 95 24 9F 27 01 00 9F 34 03 1E
03 00 9F 36 02 01 04 9F 37 04 9F A2 99 23 9F 38 00 9F 39 01 07 9F 4D 00 9F
4F 00 95 05 42 C0 00 00 00 9B 02 E8 00 8A 02 5A 33 99 00 9F 5B 00
    
```

Tags and lengths are shown in boldface. The KSN occurs in tag DFEE12. Sensitive fields (such as tag 5A) are encrypted and/or masked.

13. Appendix B: LED Behavior

Augusta devices have two LEDs: blue ICC slot LED and a tricolor status LED (blue, red, and green).

Note: A blinking red and blue tricolor LED with beeping indicates that the device has been tampered with; the ICC slot LED does not indicate tamper status.

ICC slot LED Behavior

Color	Activity	Description
Blue	Solid	Device ready for ICC insertion.
Blue	Blinking, 1s interval	Remove card.

Tricolor LED Behavior

Color	Activity	Description
Blue	Solid	Idle state; device ready for MSR or ICC functions.
Blue	Blinking, 500ms interval	Device ready for MSR swipe or ICC insertion.
Blue	Blinking, 1s interval	Remove card.
Green	Solid	Card seated.
Green	Solid, two seconds	EMV L2 transaction successful.
Red	Solid, two seconds	MagStripe read unsuccessful.
Red	Solid, two seconds	Card seated incorrectly.
Red	Solid, two seconds	Unsuccessful EMV L2 transaction.
Red	Solid until card removed	Indicates read or transaction was unsuccessful and to remove the card.
Red/Blue	Blinking red and blue, device beeps	Device tampered.
Red/Blue/Green	Blinking all colors	Load data encryption key, MAC DUKPT key, or RKI-KEK.